

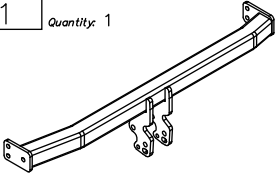

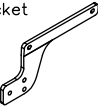





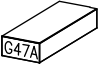

Towbar accessories:

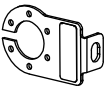
Pos. 1	Name: Main bar Quantity: 1	Pos. 5	Name: Left bracket Quantity: 1	Pos. 10	Name: Bolt 8,8 B Quantity: 6 Dim.: M10x40mm
					
Pos. 2	Name: Tow ball Quantity: 1	Pos. 6	Name: Fish-plate 1mm Quantity: 1	Pos. 11	Name: Nut 8 B Quantity: 8 Dim.: M10
					
Pos. 3	Name: Socket plate Quantity: 1	Pos. 7	Name: Fish-plate 2mm Quantity: 2	Pos. 12	Name: Washer Quantity: 4 Dim.: Ø30xØ10.5x2.5mm
					
Pos. 4	Name: Right bracket Quantity: 1	Pos. 8	Name: Distance sleeve Quantity: 4 Dim.: Ø20x4 L=57mm	Pos. 13	Name: Plain washer Quantity: 10 Dim.: Ø 10,5 mm
					
		Pos. 9	Name: Bolt 8,8 B Quantity: 4 Dim.: M10x90mm	Pos. 14	Name: Spring washer Quantity: 10 Dim.: Ø 10,2 mm
					

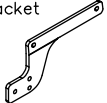

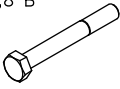
AUTO-HAK Sp. z o.o.

76-200 SŁUPSK ul. Słoneczna 16K
tel/fax (059) 8-414-414; 8-414-413
E-mail: office@autohak.com.pl
www.autohak.com.pl

Towing hitch (without electrical set)

Class: **A50-X** Cat. no. **G47A**

Designed for:

Manufacturer: **DACIA**

Model: **LOGAN I**

Type: **4 doors**

produced since 09.2004 till 06.2008

and since 07.2008 till 12.2012

Technical data:

D-value: 6,36 kN

maximum trailer weight: **1100 kg**

maximum vertical cup load: **75 kg**

Approval number according to Directive 94/20/EC: **e20*94/20*0229*00**

Foreword

This towing hitch is designed according to rules of safety traffic regulations. The towing hitch is a safety component and can be installed only by qualified personnel. Any alteration or conversion of the towing hitch is prohibited and would lead to cancellation of design certification. Remove insulating compound and underseal from vehicle (if present) in the area of the mating surfaces of the towing hitch.

The vehicle manufacturer's specifications regarding trailer mass and max. vertical cup mass are decisive for driving whereat values for the towing hitch cannot be exceeded.

D-value formula:

$$\frac{\text{Max trailer weight [kg]} \times \text{Max vehicle weight [kg]}}{\text{Max trailer weight [kg]} + \text{Max vehicle weight [kg]}} \times \frac{9,81}{1000} = D \text{ [kN]}$$

FITTING INSTRUCTION

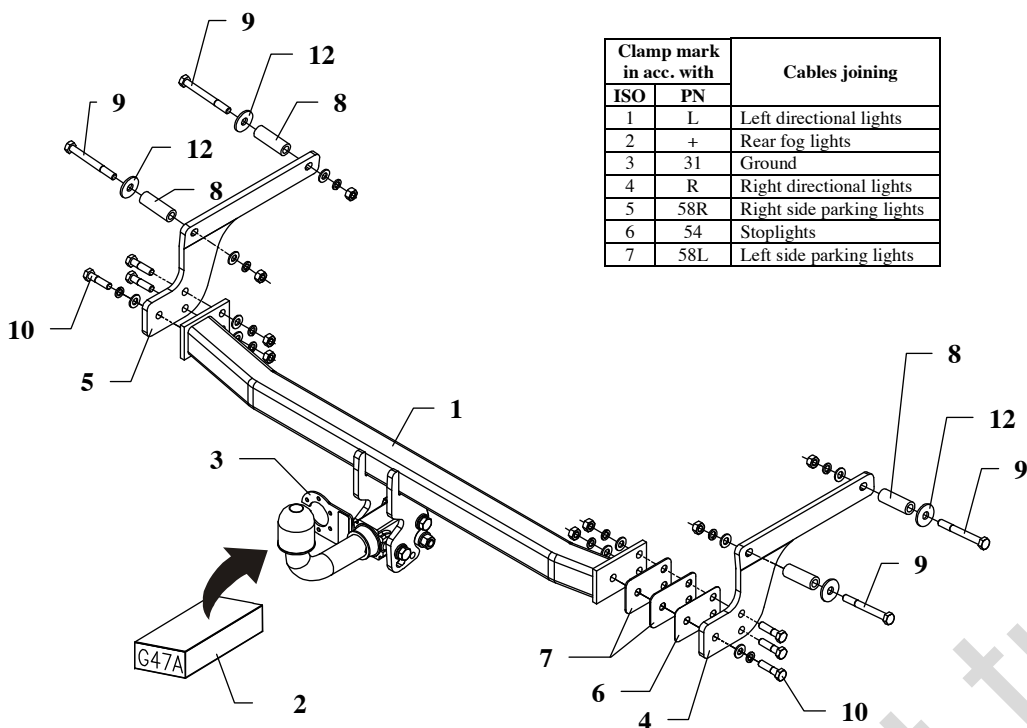

This towbar is designed to assembly in following car: **DACIA LOGAN I, 4 doors**, produced since 09.2004 till 06.2008 and since 07.2008 till 12.2012, catalogue number **G47A** and is prepared to tow trailers max total weight **1100 kg** and max vertical load **75 kg**.

From manufacturer

Thank you for buying our product. Their reliability has been confirmed in many tests. Reliability of towbar depends also on correct assembly and right exploit. For this reasons we kindly ask to read carefully this instruction and apply to hints.

The towbar should be install in points described by a car producer.

Fitting instructions

1. To install this towbar find plugged holes in the trunk (per two each side). Remove plugs.
2. To holes (from inside) put distance sleeves (pos. 8) with big washers (pos. 12) and bolts M10x90mm (pos. 9) as show on the drawing.
3. From below the car, on protruding bolts M10 put side brackets (pos. 4 and 5). Fix loosely.
4. Between mounted side brackets (pos. 4 and 5) put main bar of the towbar (pos. 1) and fix with bolts M10x40mm (pos. 10) according to drawing. Remember about fish-plates (pos. 6 and 7) on the right side!
5. Tighten all bolts according to the torque show in the table.
6. Fix body of the automat and place tow-ball according to supplied instruction. Note! Remember to place socket plate (pos. 3) as shown on the drawing.
7. Connect electric wires of 7-pole socket according to the instruction of the car. (Recommend to make at authorized service station)
8. Complete paint layer damaged during installation.

Torque settings for nuts and bolts (8,8):

M 8	25 Nm	M 10	55 Nm
M 12	85 Nm	M 14	135 Nm

NOTE

After install the towbar you should get adequate note in registration book (at authorised service station).The car should be equipped with:

- Indicators
- Tow mirrors

After 1000km check all bolts and nuts. The ball of towbar must be always kept clear and conserve with a grease.