

AUTO-HAK Sp. z o.o.

ul. Słoneczna 16K 76-200 SŁUPSK
POLAND

tel/fax +48 59 8 414 414; +48 59 8 414 413

e-mail: office@autohak.com.pl

www.autohak.com.pl



AUTO-HAK



CITROEN C5 II

4D, 1 rura wydechowa/
single exhaust pipe



04.2008 →

PEUGEOT 407 4D



10.2008 → 02.2011

Cat. no:

P35A

e20

e20*94/20*1472*00



2h

D

10,4 kN

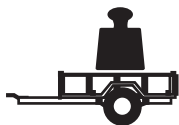

R=2100 kg



S=80 kg

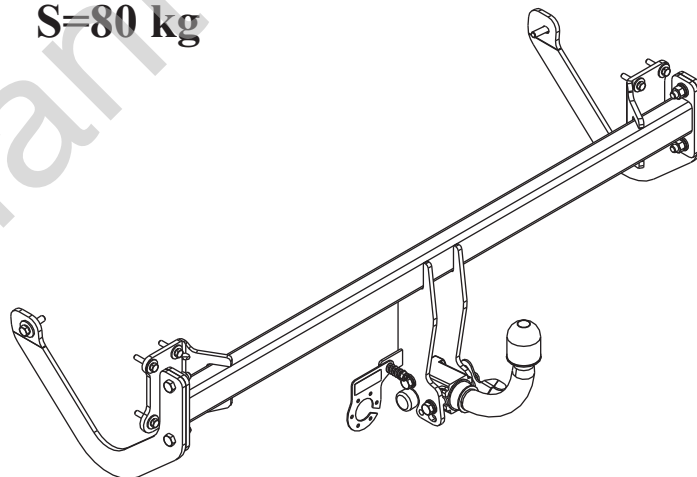

M6 - 11 Nm
M10 - 50 Nm
M14 - 138 Nm

M8 - 25 Nm
M12 - 87 Nm
M16 - 210 Nm









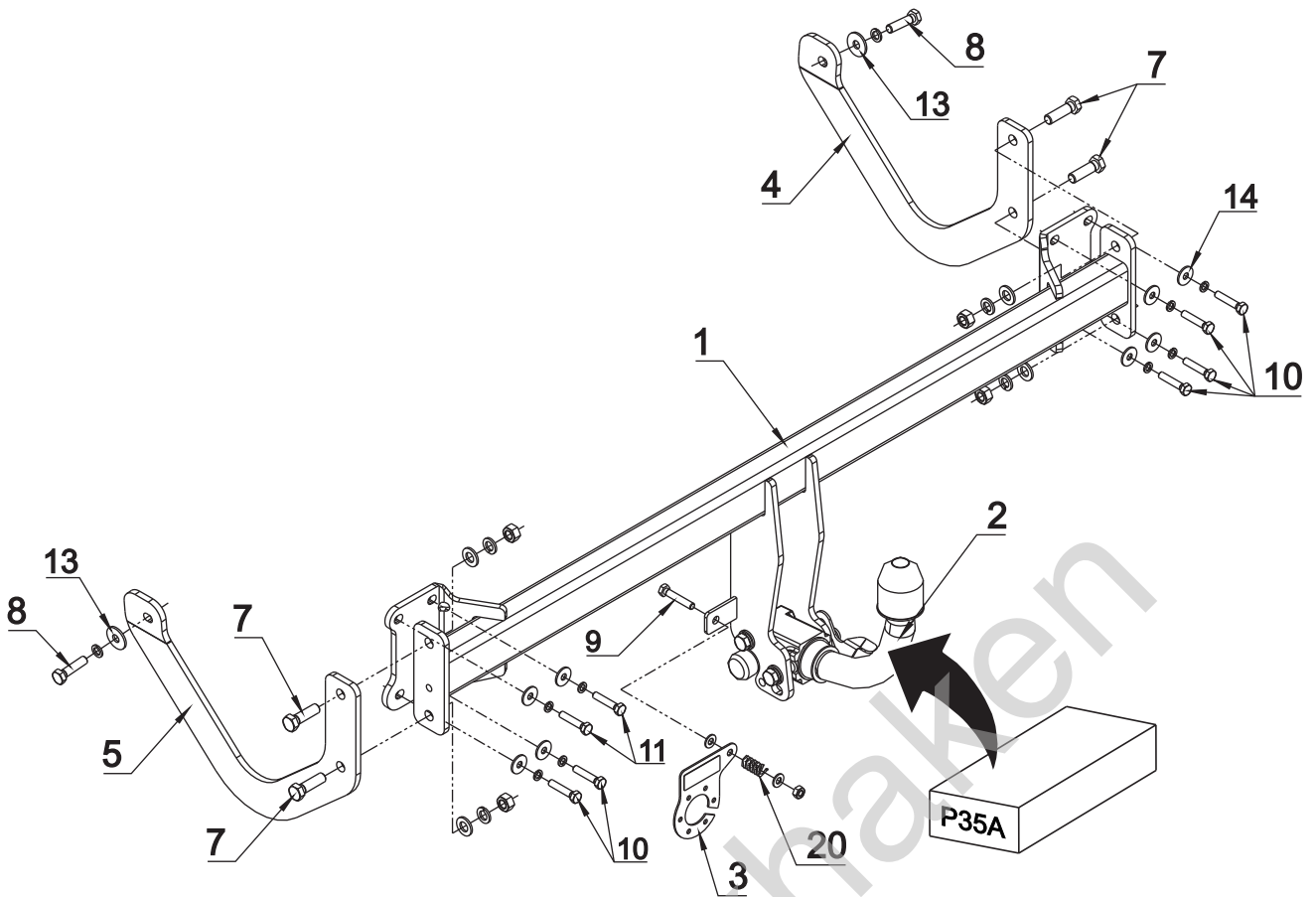

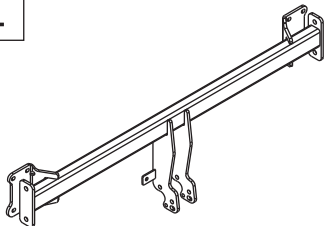

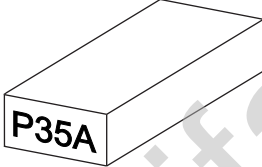
0 km →



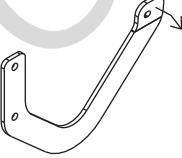
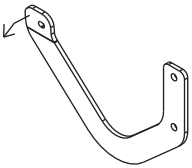

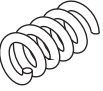
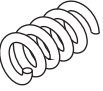

1000 km

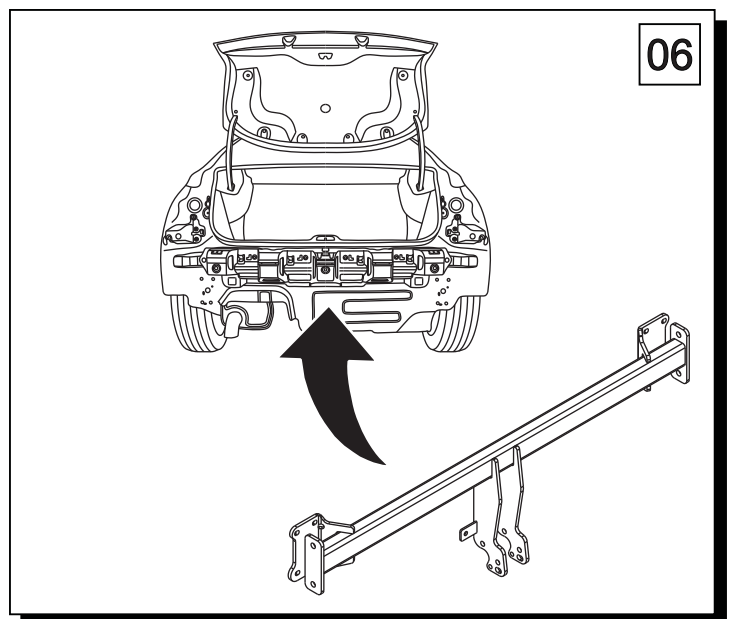
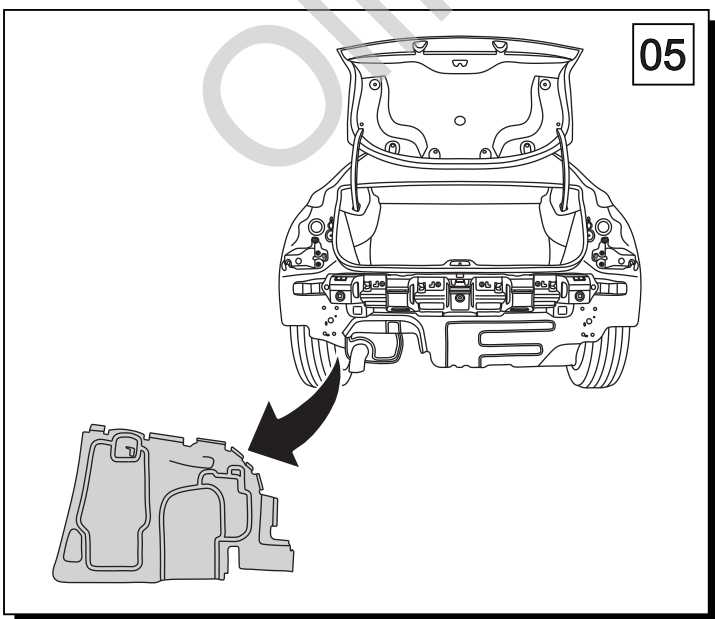
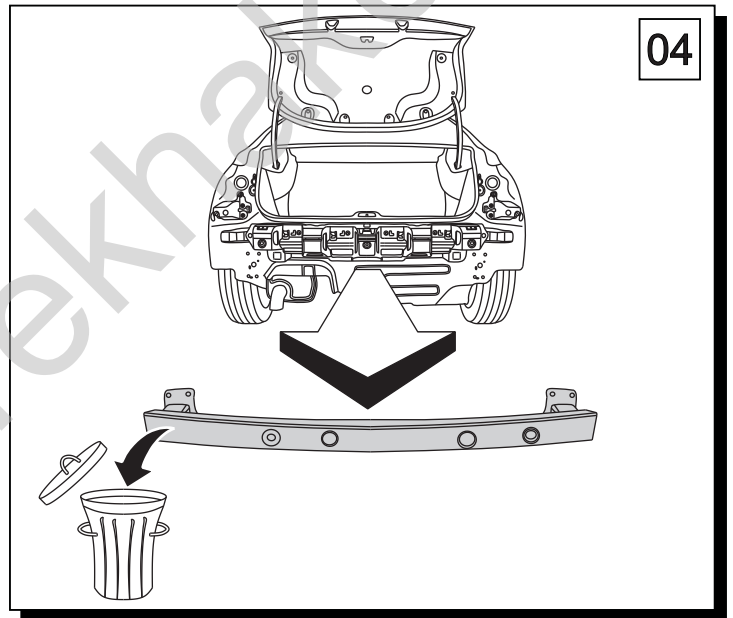
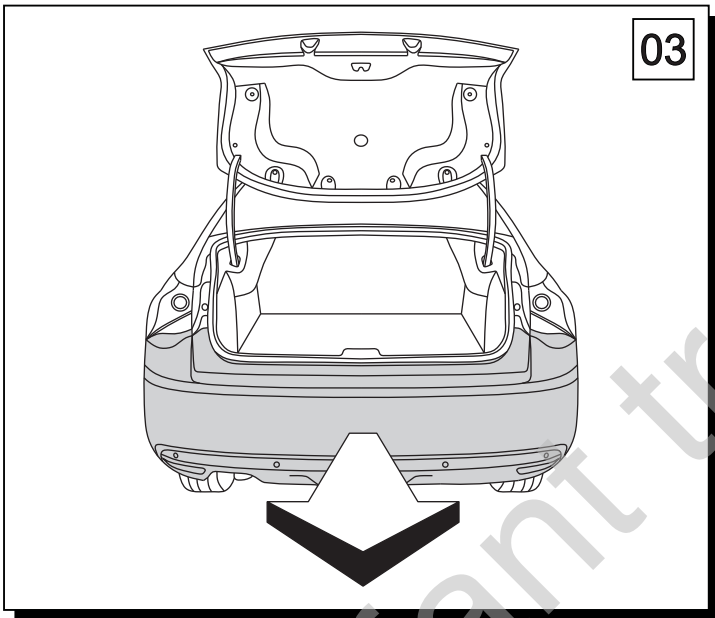
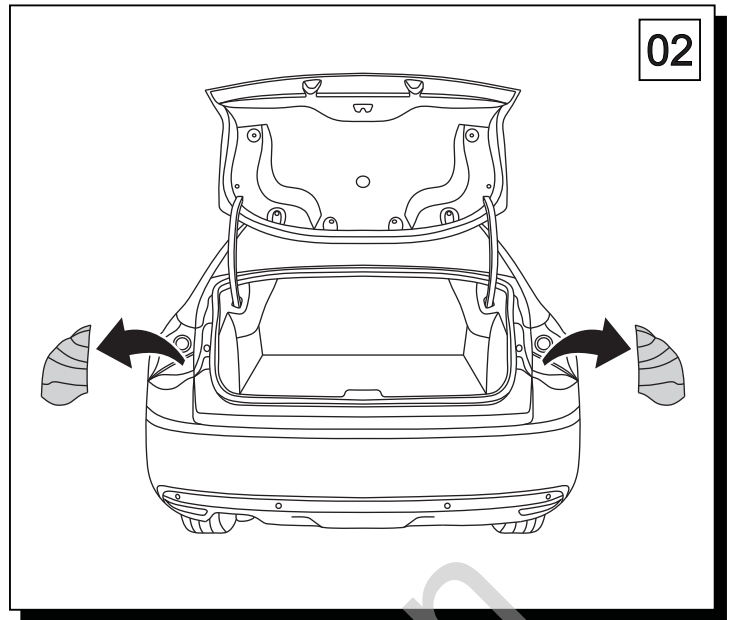
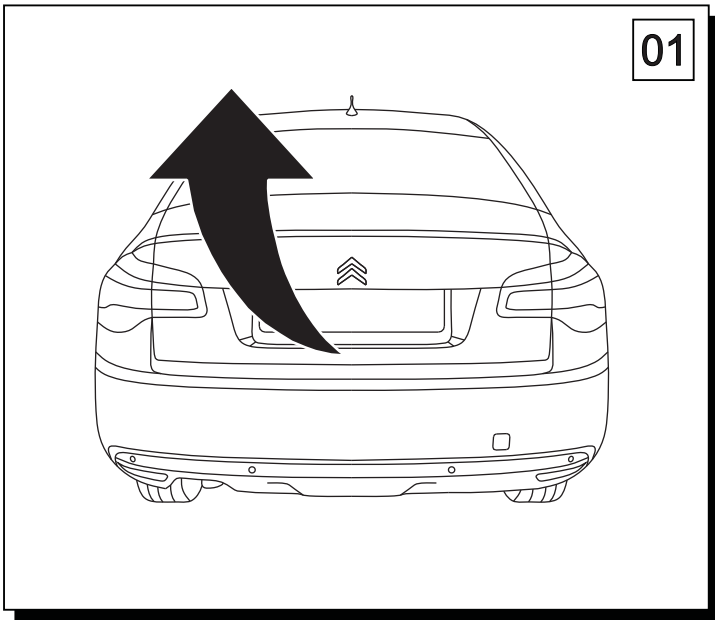

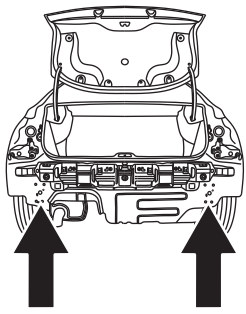
 1	x 1		7 M12x40	x 4
			8 M10x40	x 2
			9 M8x45	x 1
			10 M8x40	x 8
 2 Art.nr-KL1P35A	x 1		11 ϕ 13	x 2
			12 ϕ 30x ϕ 10.5x2.5 10 (DIN 9021)	x 2
			13 ϕ 24x ϕ 8.5x2 8 (DIN 9021)	x 8
 3 Art.nr-BL1P35A	x 1		14 ϕ 8.4	x 2
 4	x 1		15 ϕ 12.2	x 4
			16 ϕ 10.2	x 2
			17 ϕ 8.2	x 8
 5	x 1		18 M12	x 4
			19 M8	x 1
 20	x 1			x 1
 6	x 1			







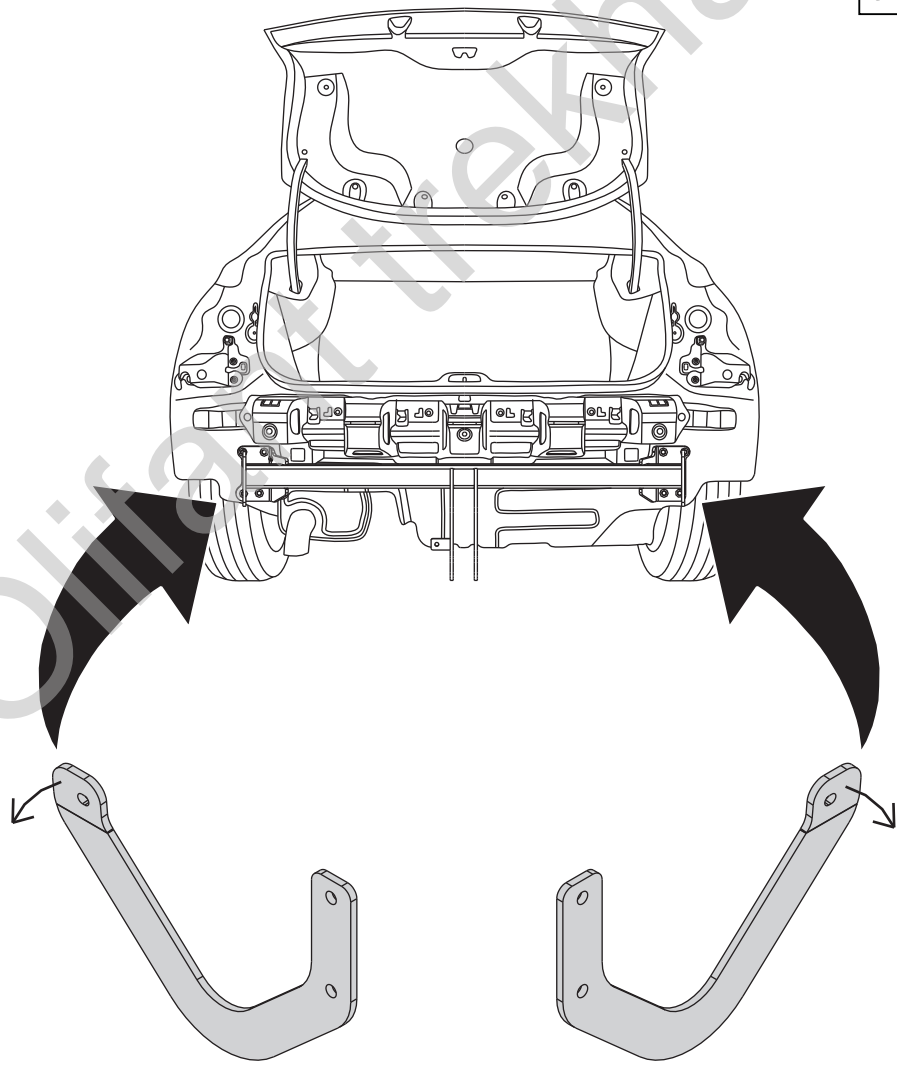
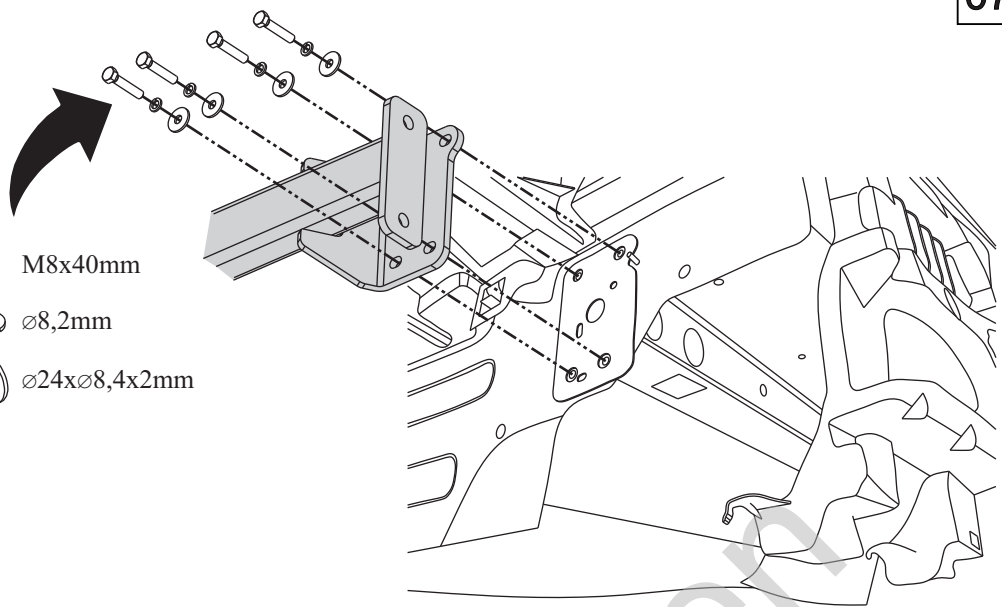

- 4x  M8x40mm
- 4x  $\varnothing 8,2\text{mm}$
- 4x  $\varnothing 24 \times \varnothing 8,4 \times 2\text{mm}$

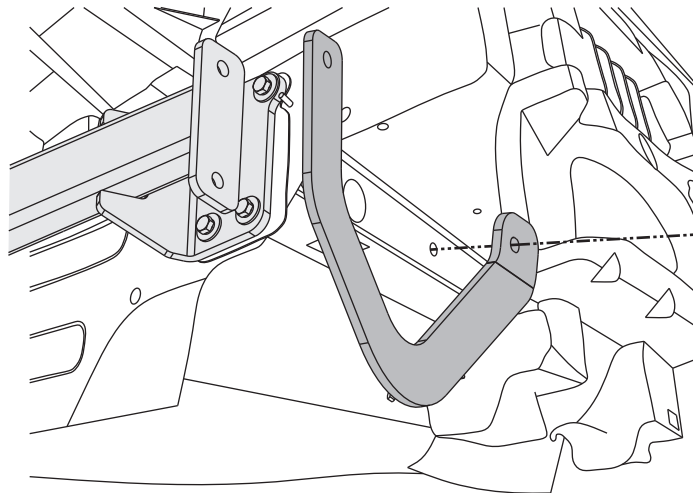
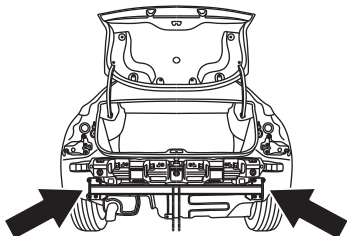

09



- 1x  M10x40mm
- 1x  $\varnothing 10,2\text{mm}$
- 1x  $\varnothing 30 \times \varnothing 10,5 \times 2,5\text{mm}$

10

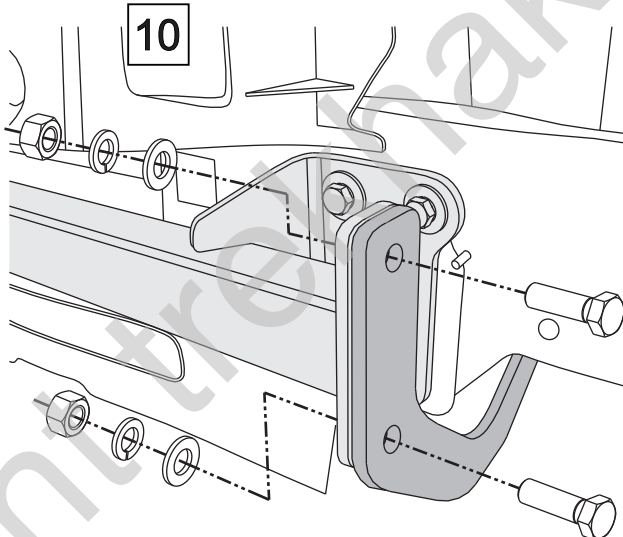
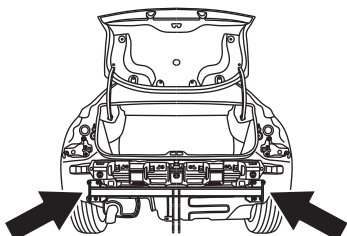

- 2x  $\varnothing 13\text{mm}$
- 2x  $\varnothing 12,2\text{mm}$
- 2x  M12

- 2x  M12x40mm

11

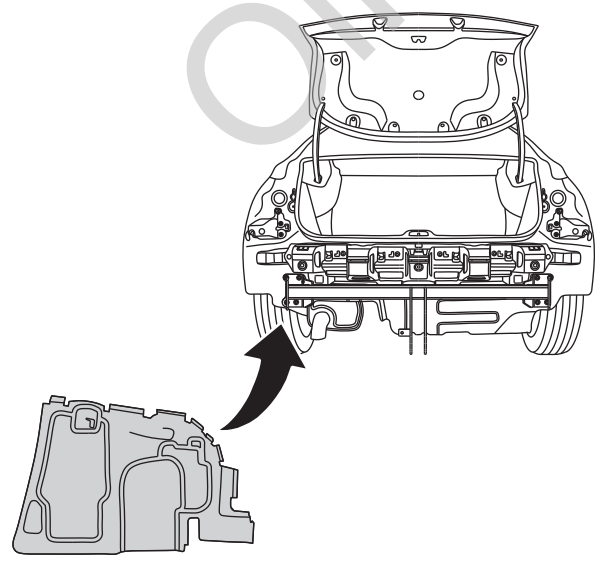

12

