



TREKHAKEN • ATTELAGES • ANHÄNGERVORRICHTUNGEN • TOWBARS • ENHANCES • ANHÆNGERTRÆK

Montagehandleiding | instructions de montage | Einbauanleitung | Mounting instruction
Instrucciones de montaje | monteringsvejledning





BMW 2 Active Tourer (type U06)

11/'21 -

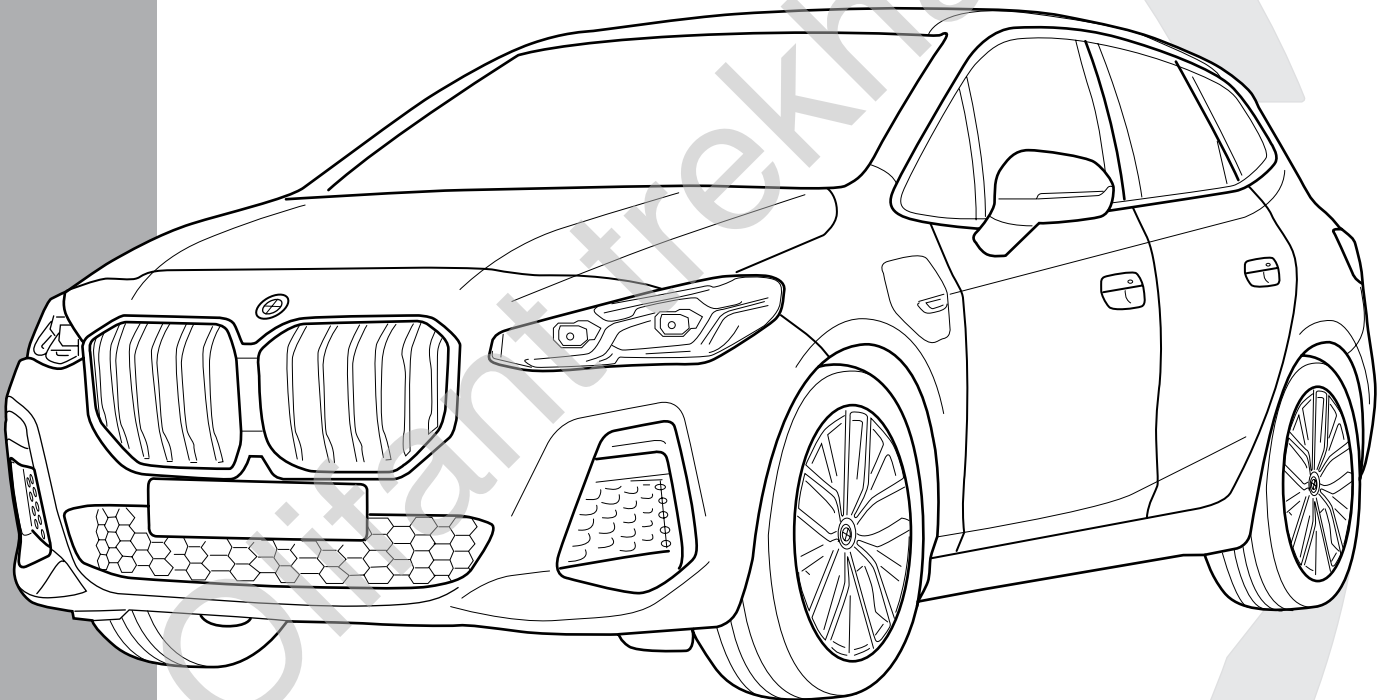
- ✓ STANDARD
- ✓ LUXURY
- ✗ M SPORT PACKAGE
- ✓ KICK SENSOR
- ✓ AD BLUE

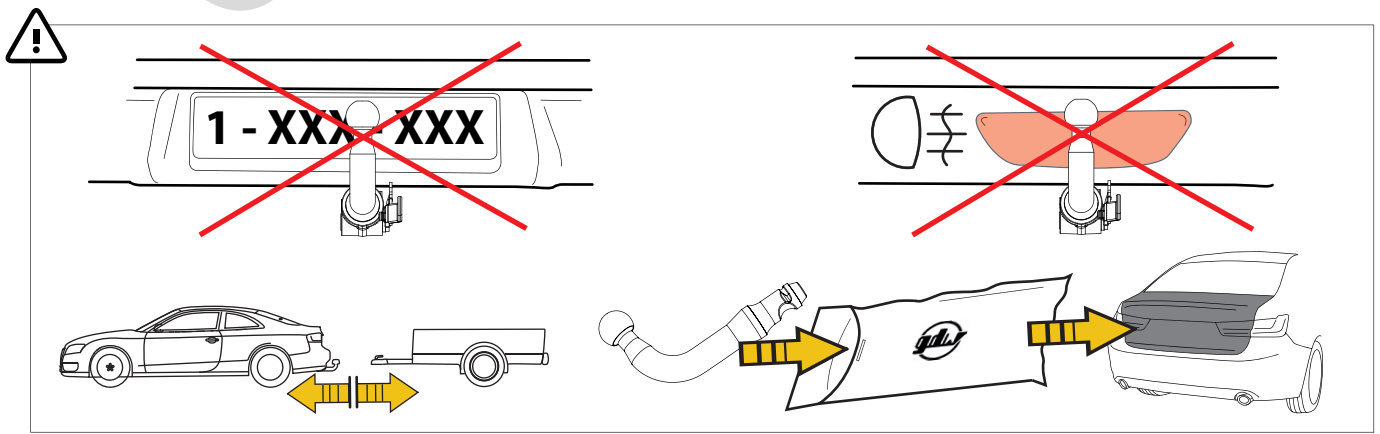
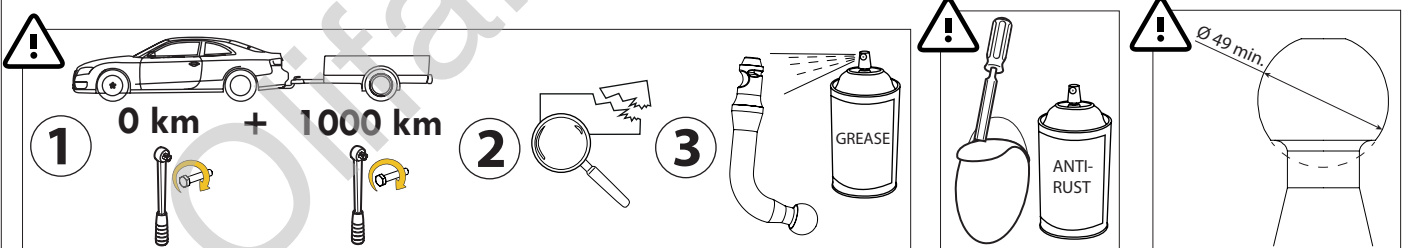
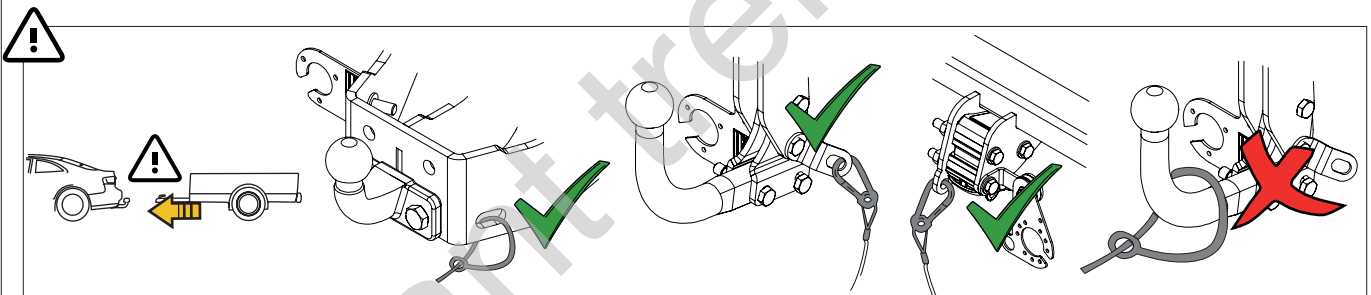
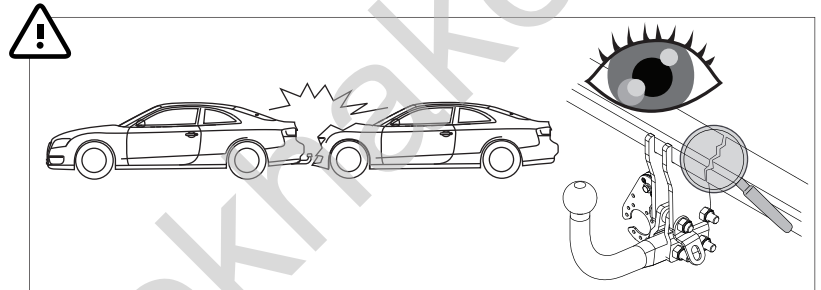
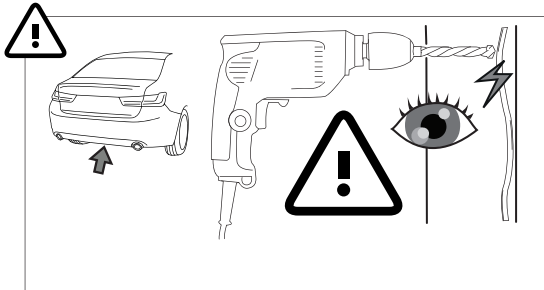
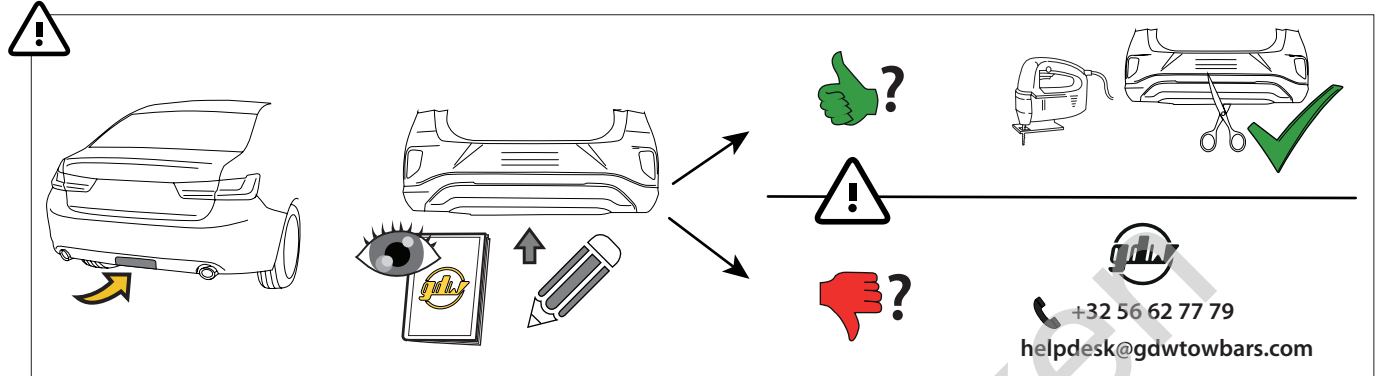
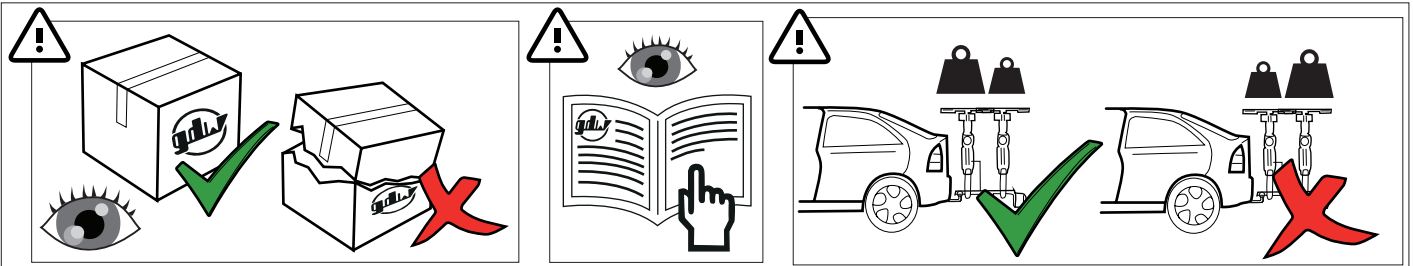



MADE BY 	D 10,35	F	E6
BELGIUM	S 120	EC-N° 55R-02 1721	
REF N° 2662T60		SERIAL N° XXXX	
DESCRIPTION BMW Active Tourer 11/'21-			



$$D = \frac{\text{max kg (car)} \times \text{max kg (trailer)}}{\text{max kg (car)} + \text{max kg (trailer)}} \times 0.00981 \leq 10,35 \text{ kN}$$

$$S = \begin{matrix} \downarrow \\ \text{hook} \end{matrix} \leq 120 \text{ kg} \quad \begin{matrix} \downarrow \\ \text{trailer} \end{matrix} \leq 2100 \text{ kg}$$

See the Certificate Of Conformity (COC) of your vehicle or contact your dealer to verify the max. trailer weight of your car!

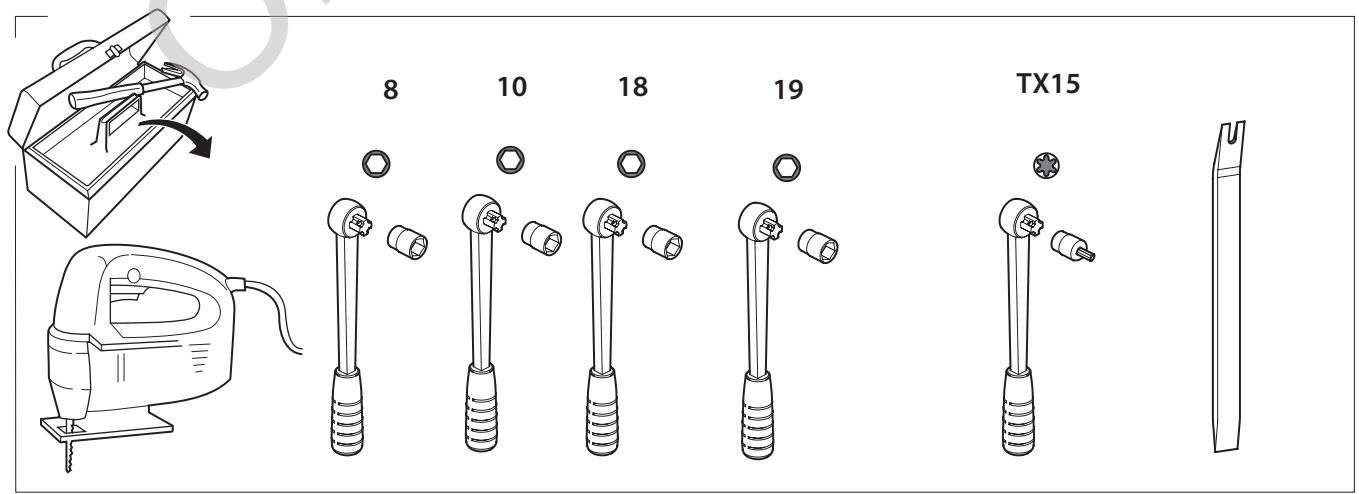
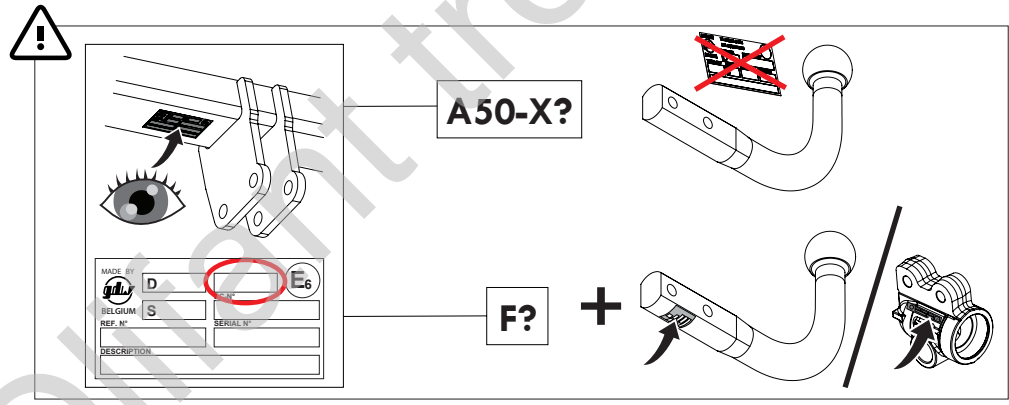
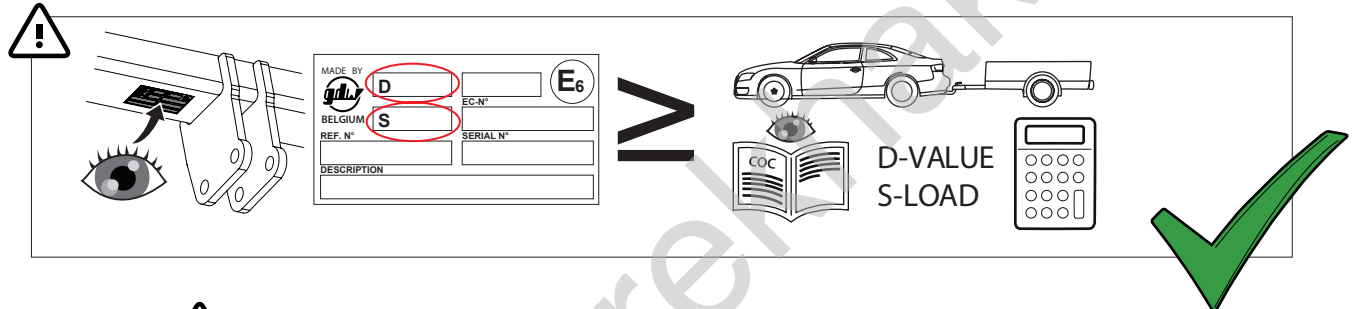
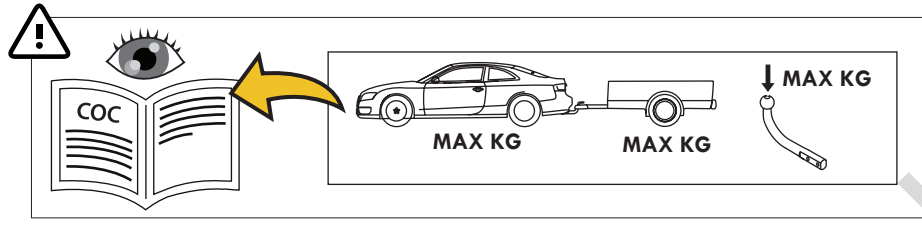

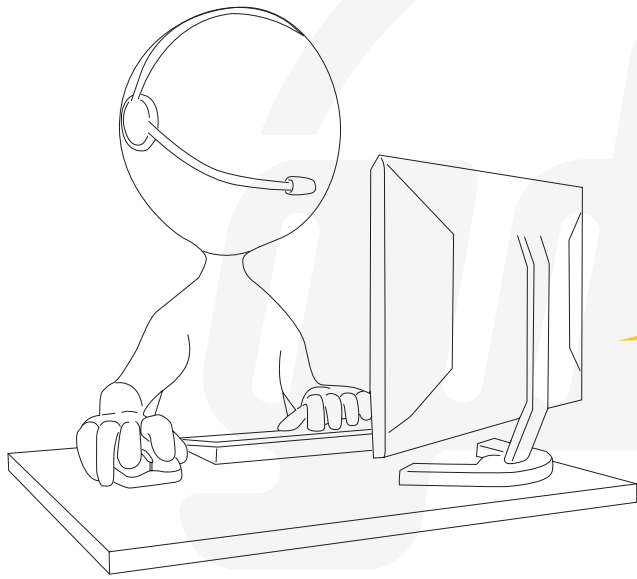

helpdesk@gdwtowbars.com

+32 56 62 77 79

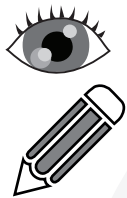

Monday	08:00 - 12:00	12:30 - 16:30
Tuesday	08:00 - 12:00	12:30 - 16:30
Wednesday	08:00 - 12:00	12:30 - 16:30
Thursday	08:00 - 12:00	12:30 - 16:30
Friday	08:00 - 12:00	12:30 - 15:30



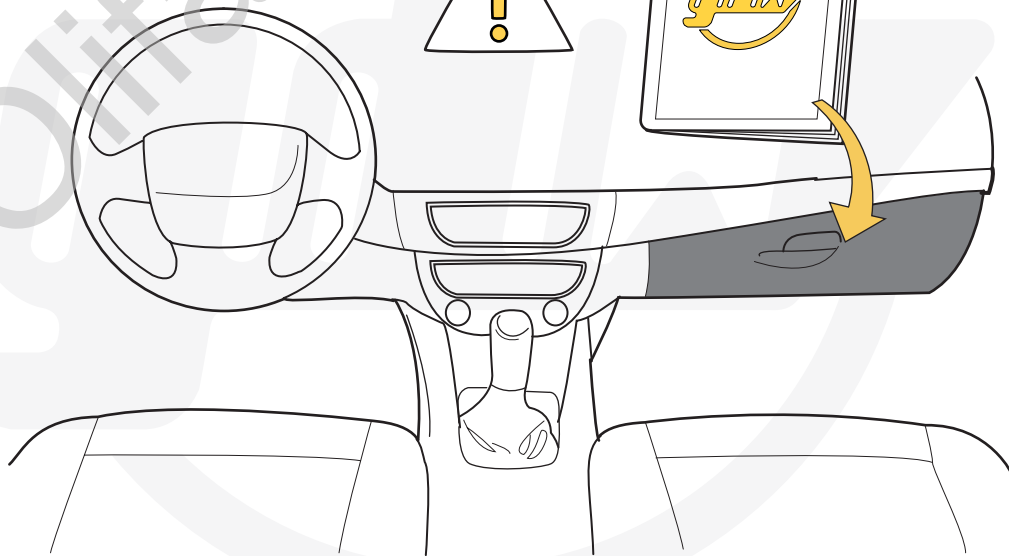

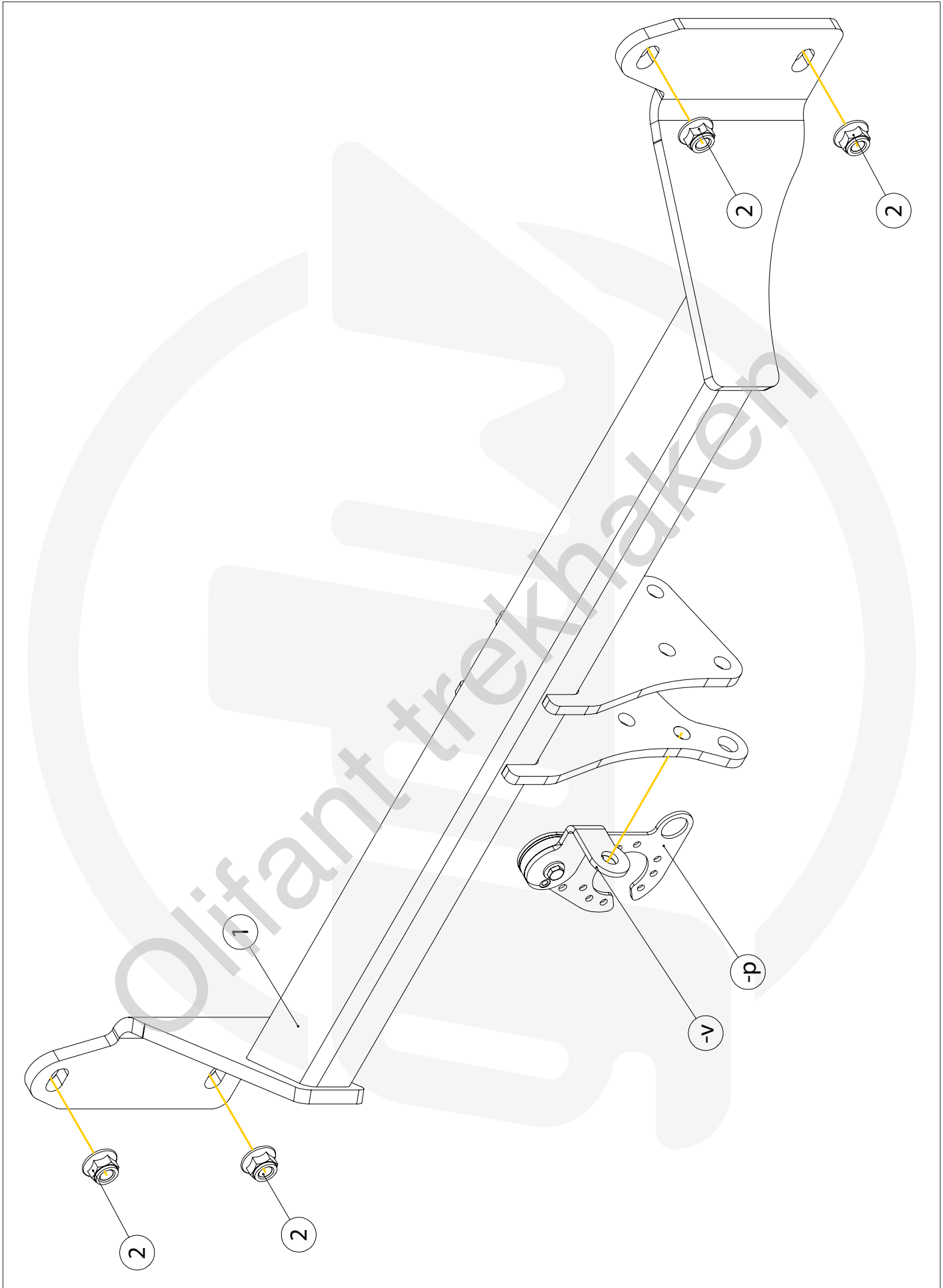

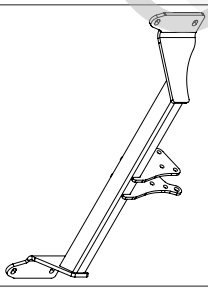

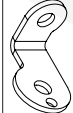

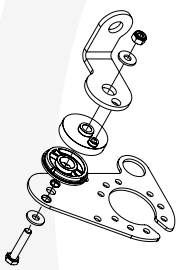



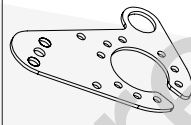

KEY NUMBER

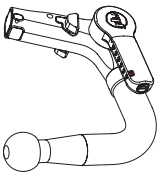

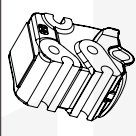
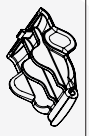

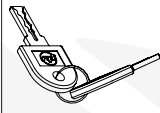
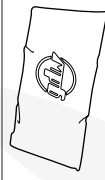
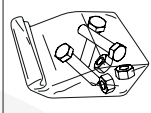
1		X1	GDW REF. 2662160
2		X1	MBN13023-M12 X 1,5 KL10
-V		X1	GDW REF. 908.095

P		X1	GDW REF. P39
↑		X1	DIN985-M6
↑		X2	6,2 X 15,4 X 1,6 (NYLON)
↑		X1	GDW REF. 718.16.002
↑		X1	GDW REF. 718.16.003
↑		X1	GDW REF. 908.094
↑		X1	DIN933-M6 X 30
↑		X1	GDW REF. 908.095

Geleverd met - Livré avec - Delivered with Gefiefert mit - Elementos adjuntos - Levers med		X1	GDW REF. 960.V0612
↑		X1	GDW REF. 740.200
↑		X1	GDW REF. 912.003
↑		X1	GDW REF. 740.112
↑		X1	GDW REF. 740.111
↑		X1	GDW REF. 740.12X X=LAST NUMBER ON KEY
↑		X1	GDW REF. 718.15.001
↑		X1	GDW REF. SYST60-10
↑		X3	DIN931-M12X110-8.8
↑		X3	DIN128A-M12
↑		X6	DIN125A-M12
↑		X3	DIN934-M12

1

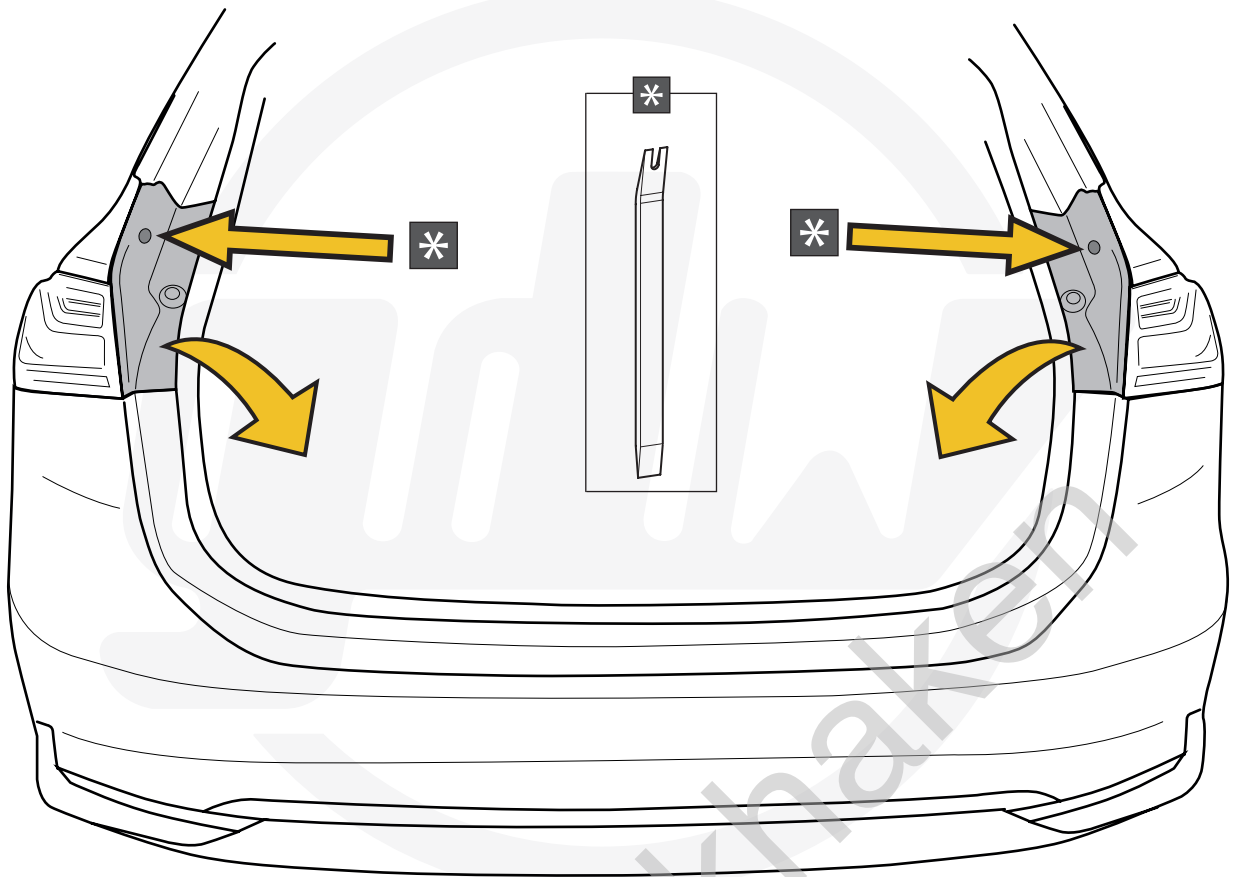

2

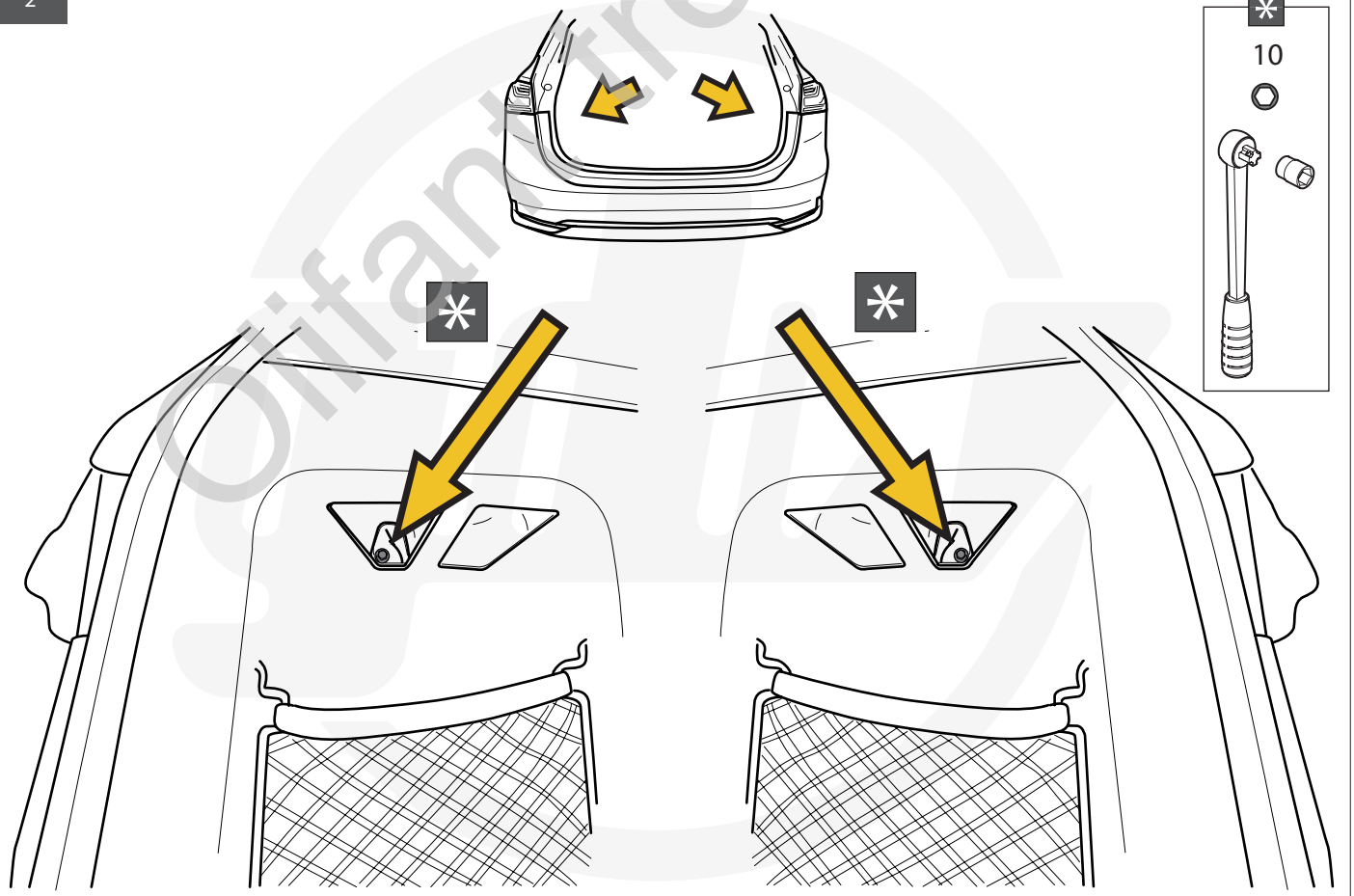

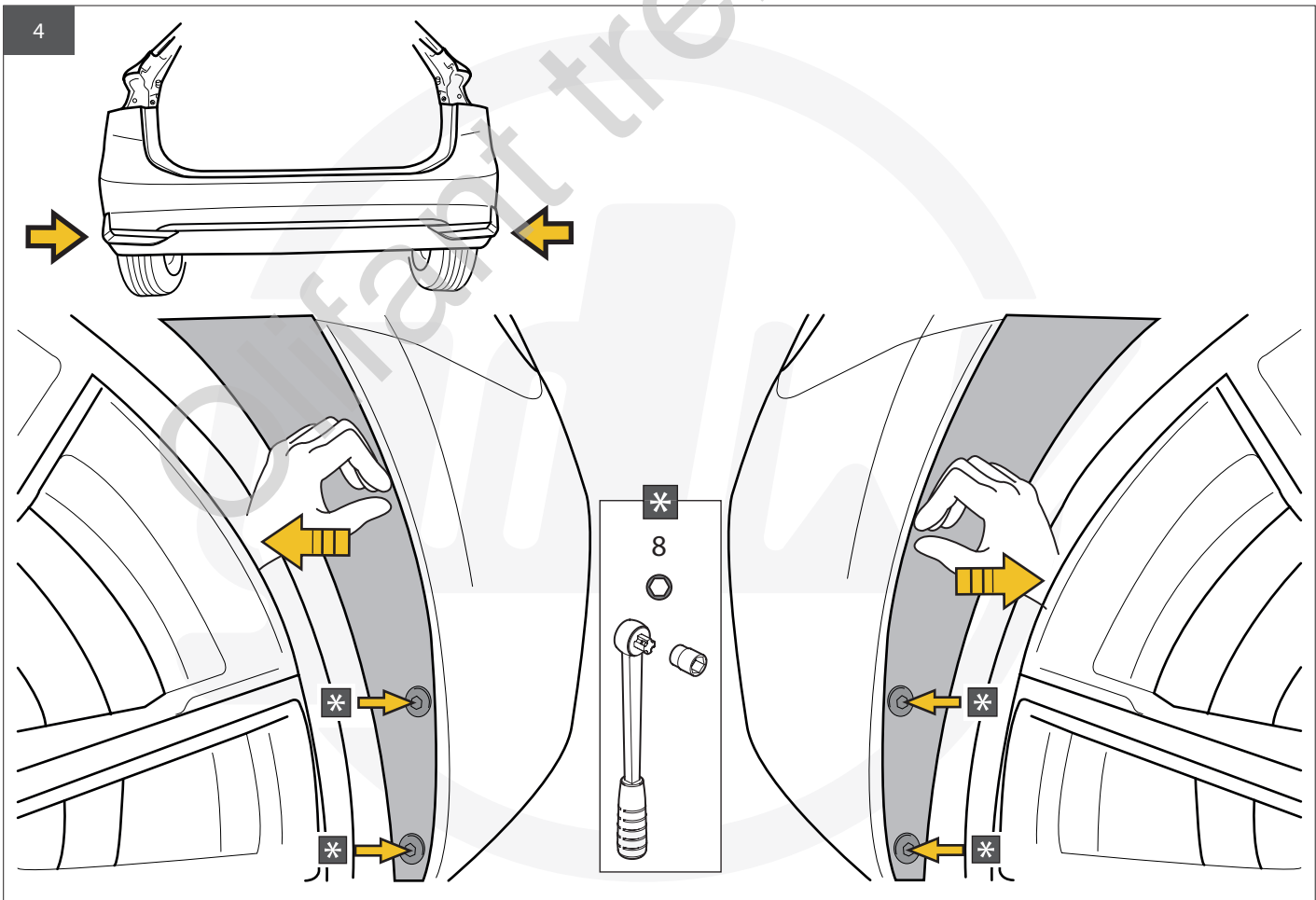
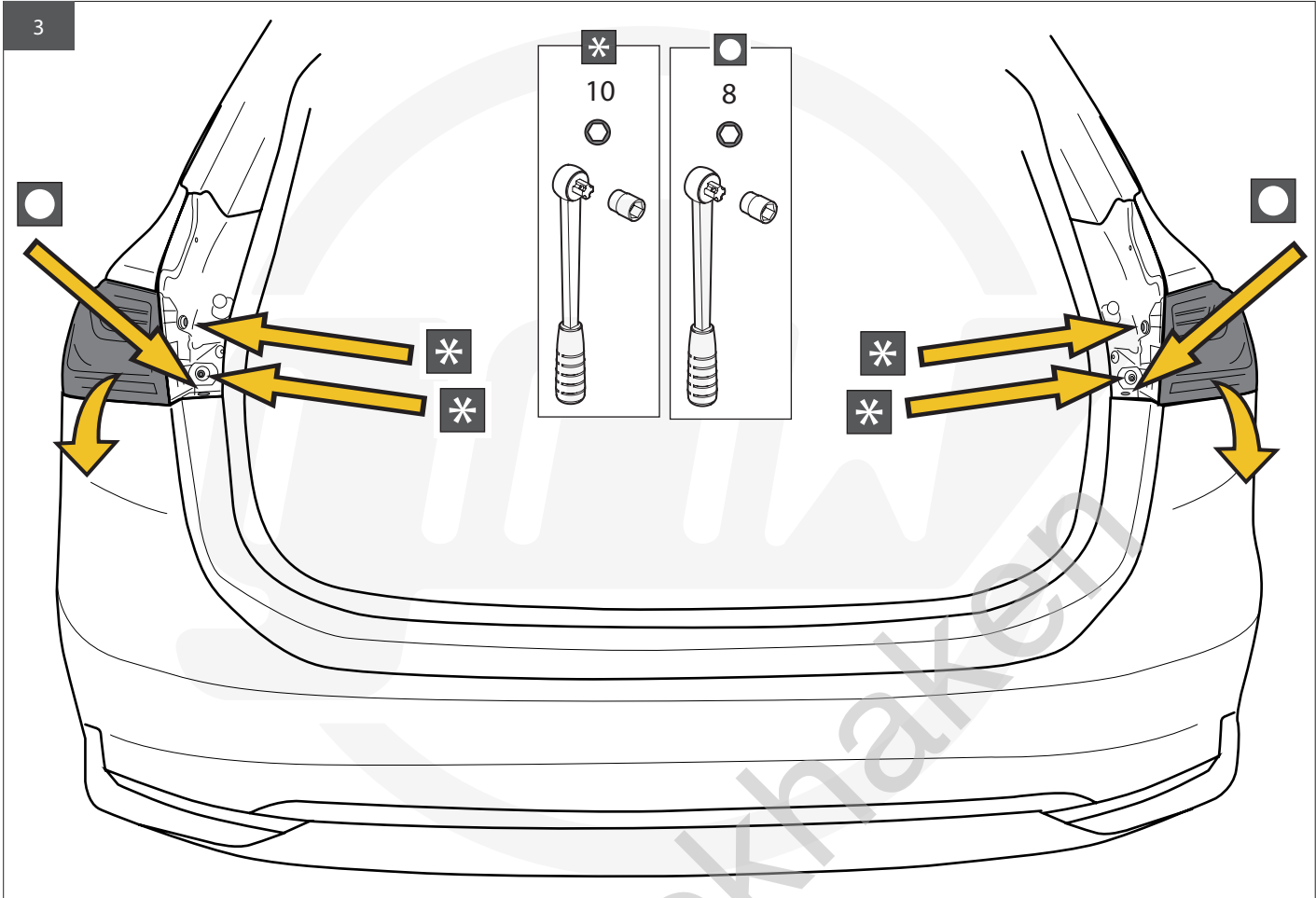

5

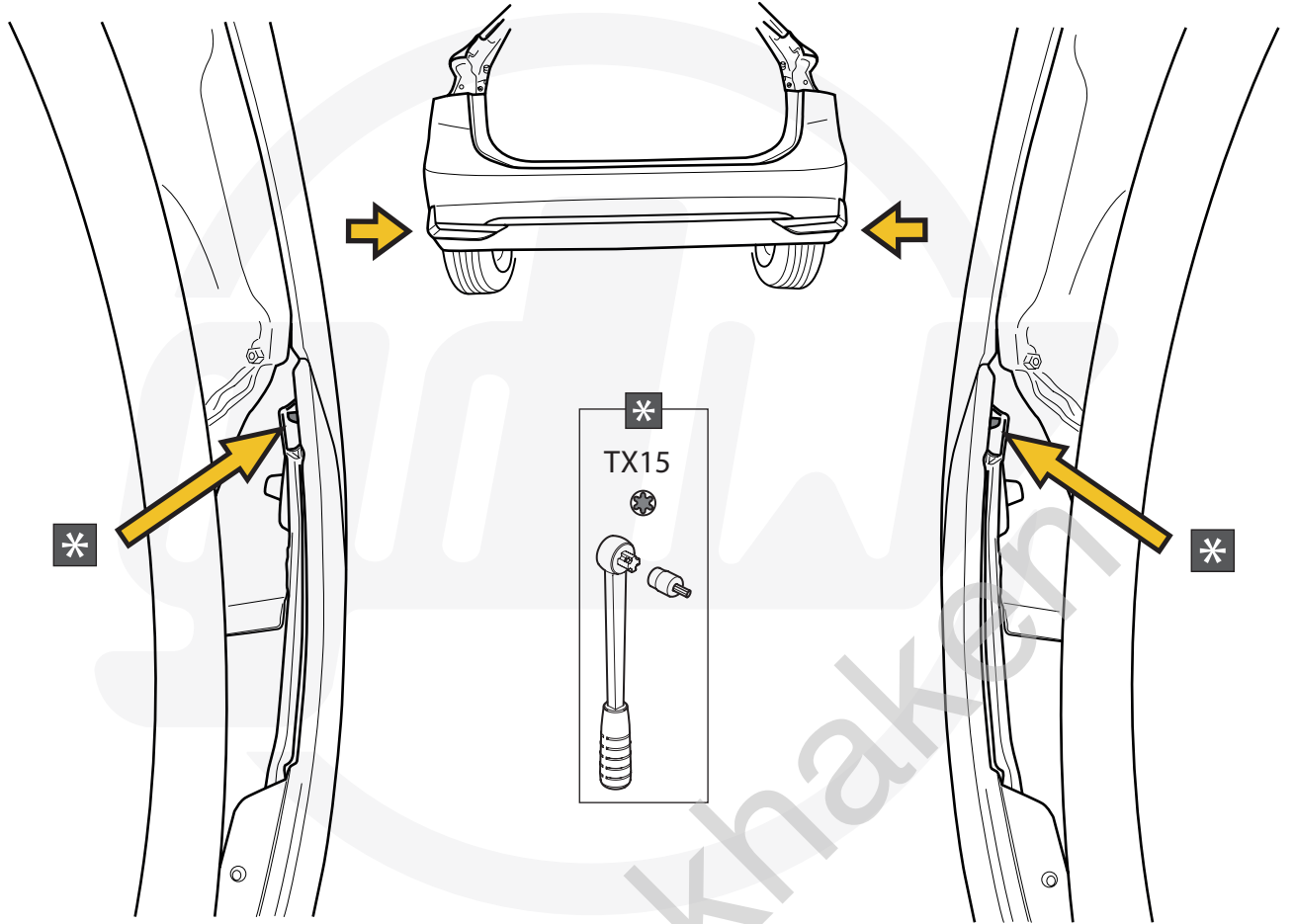

6

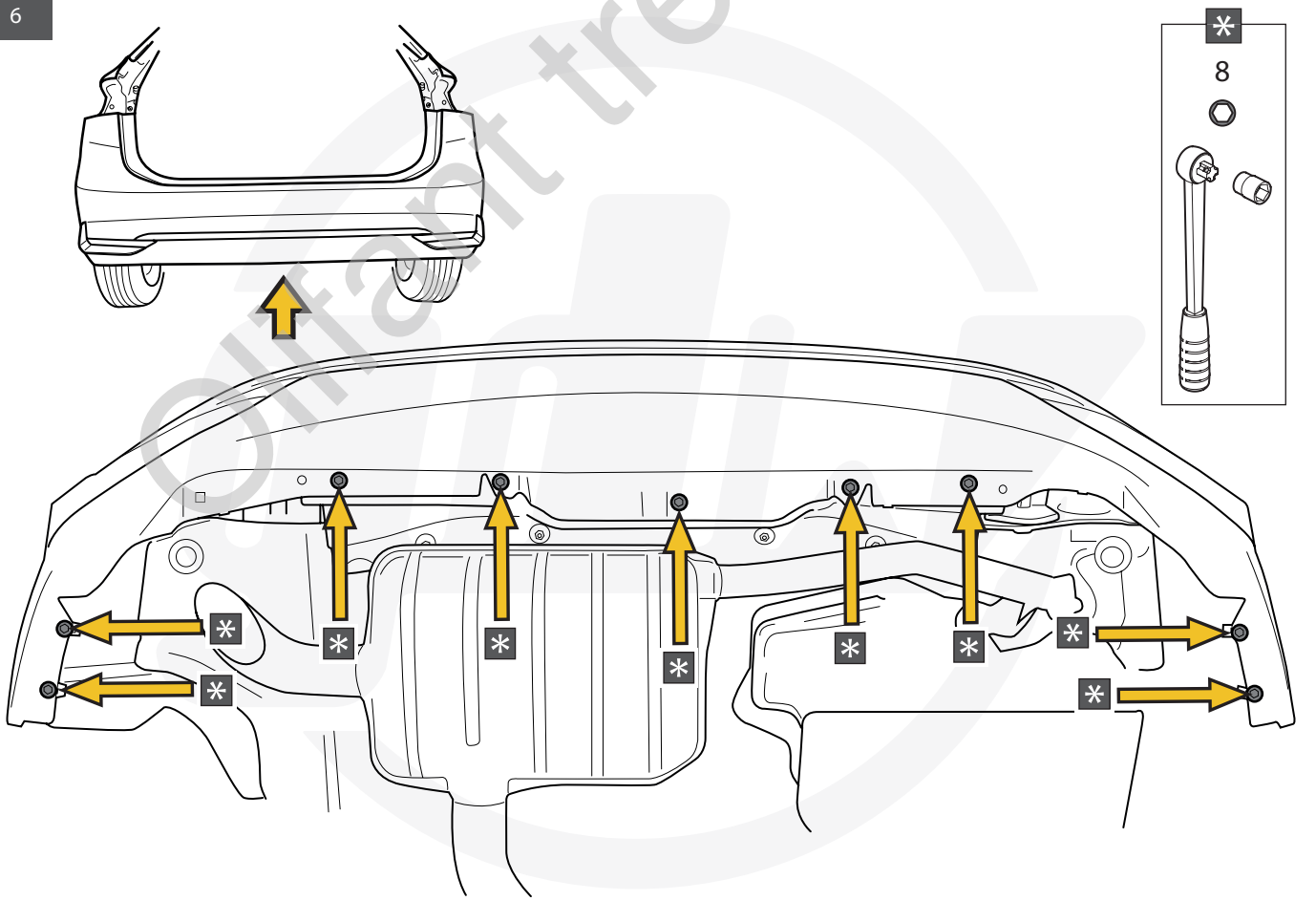

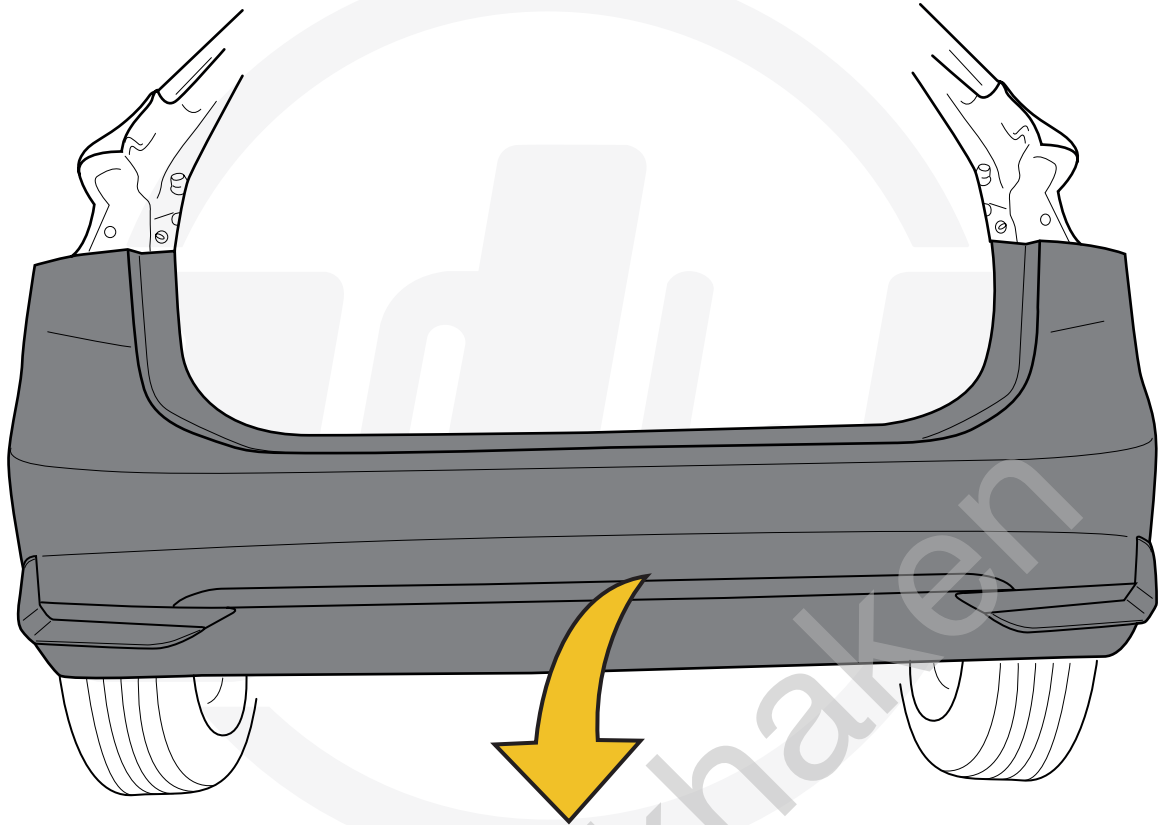

VEHICLES WITH KICK SENSOR

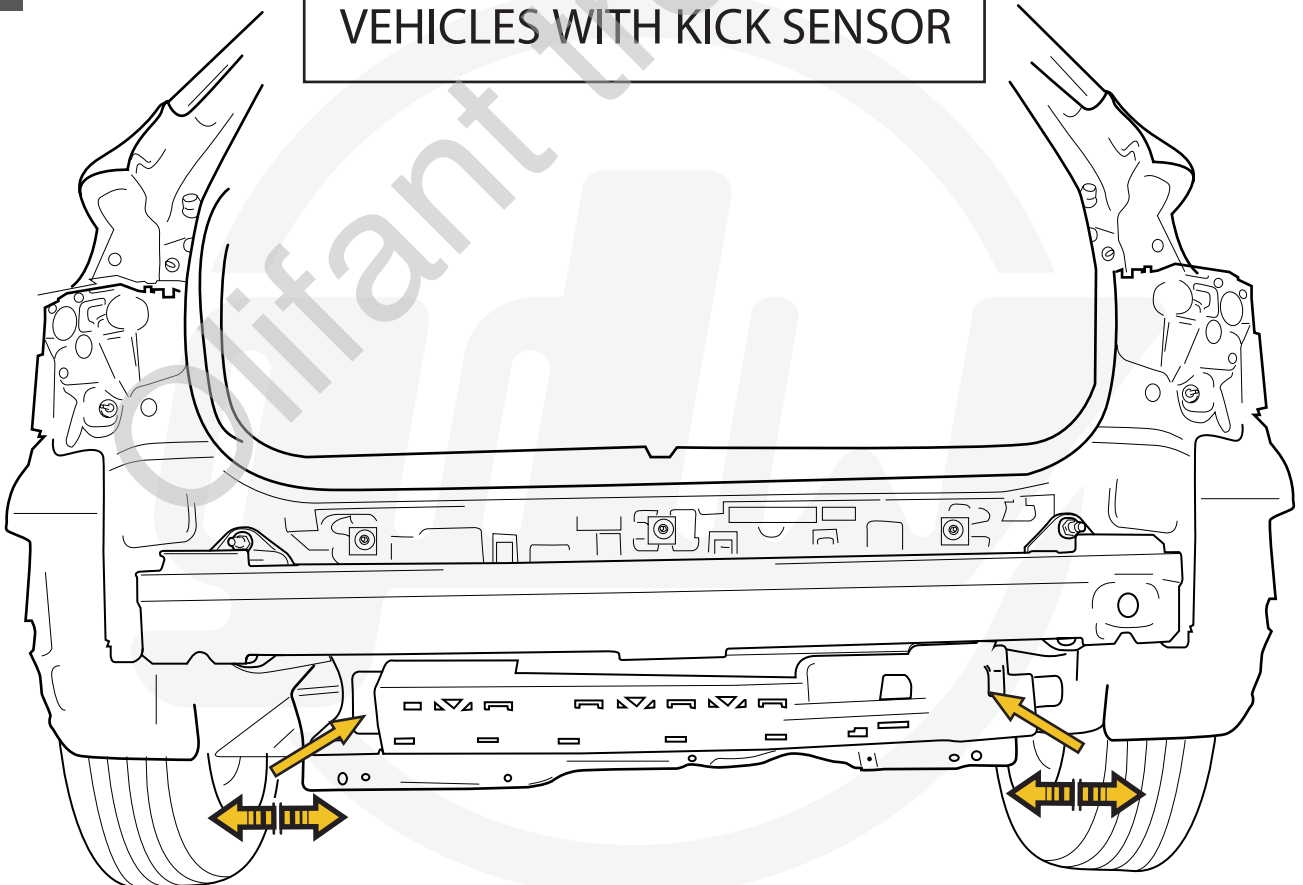

VEHICLES WITH KICK SENSOR

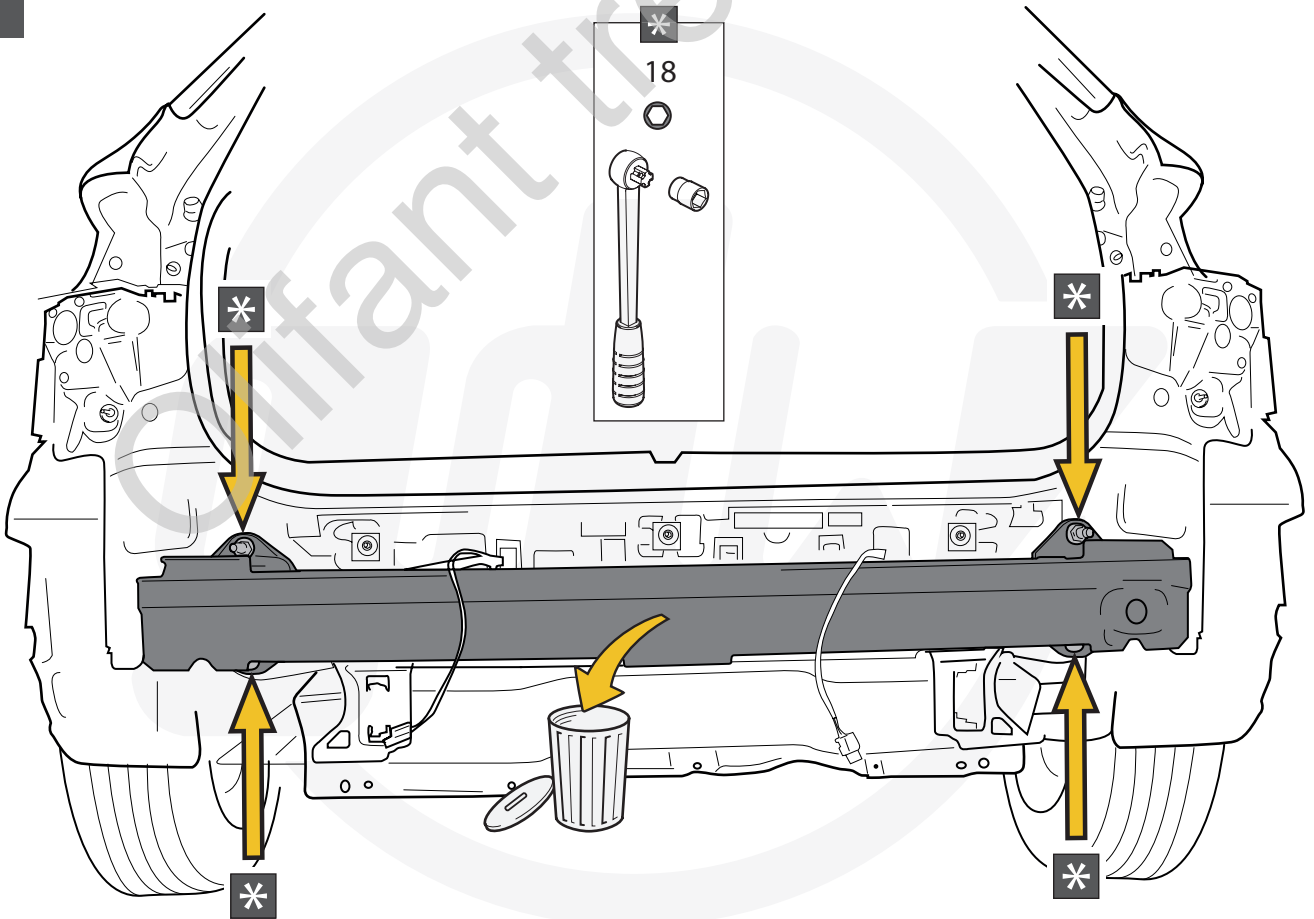
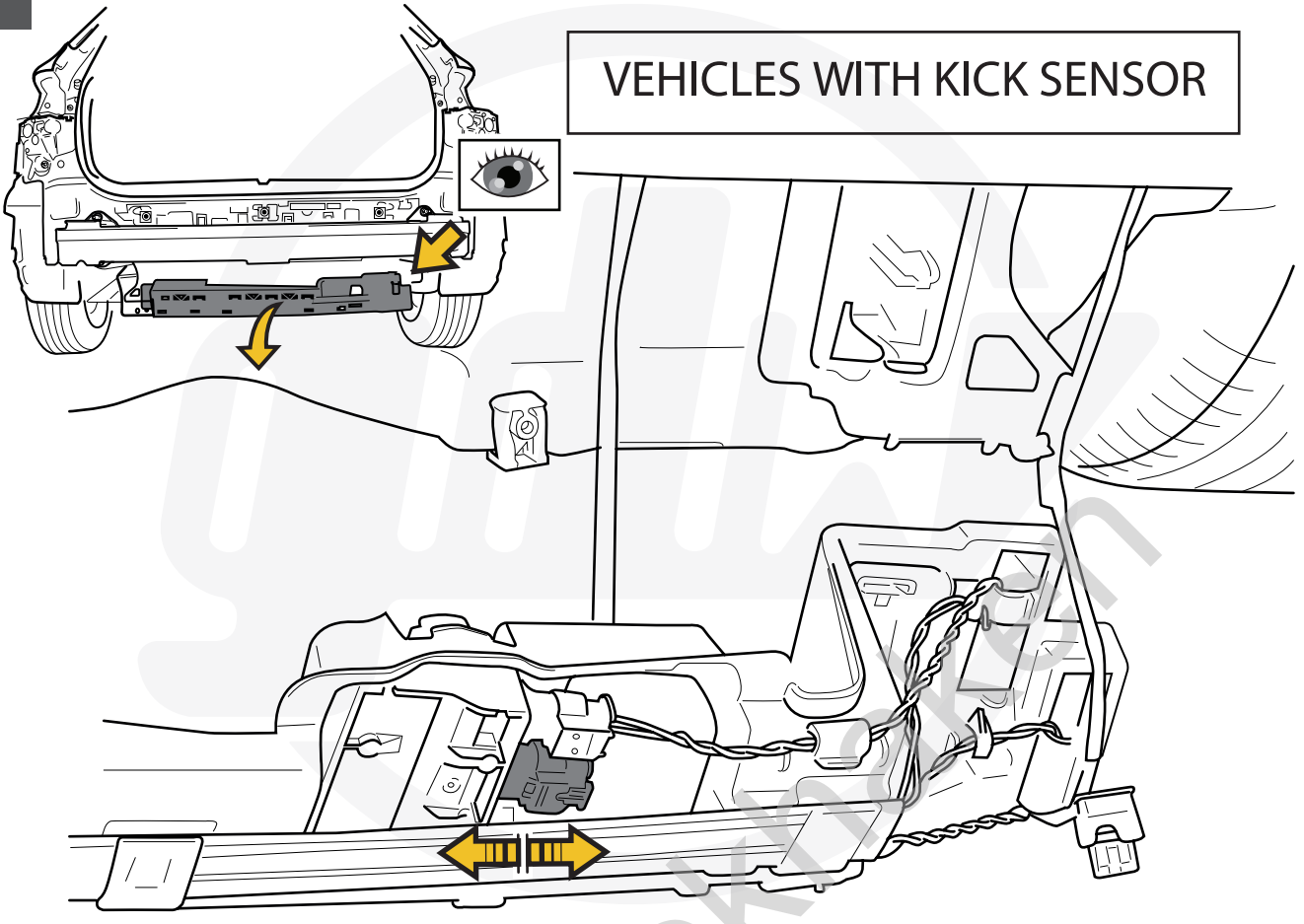

11

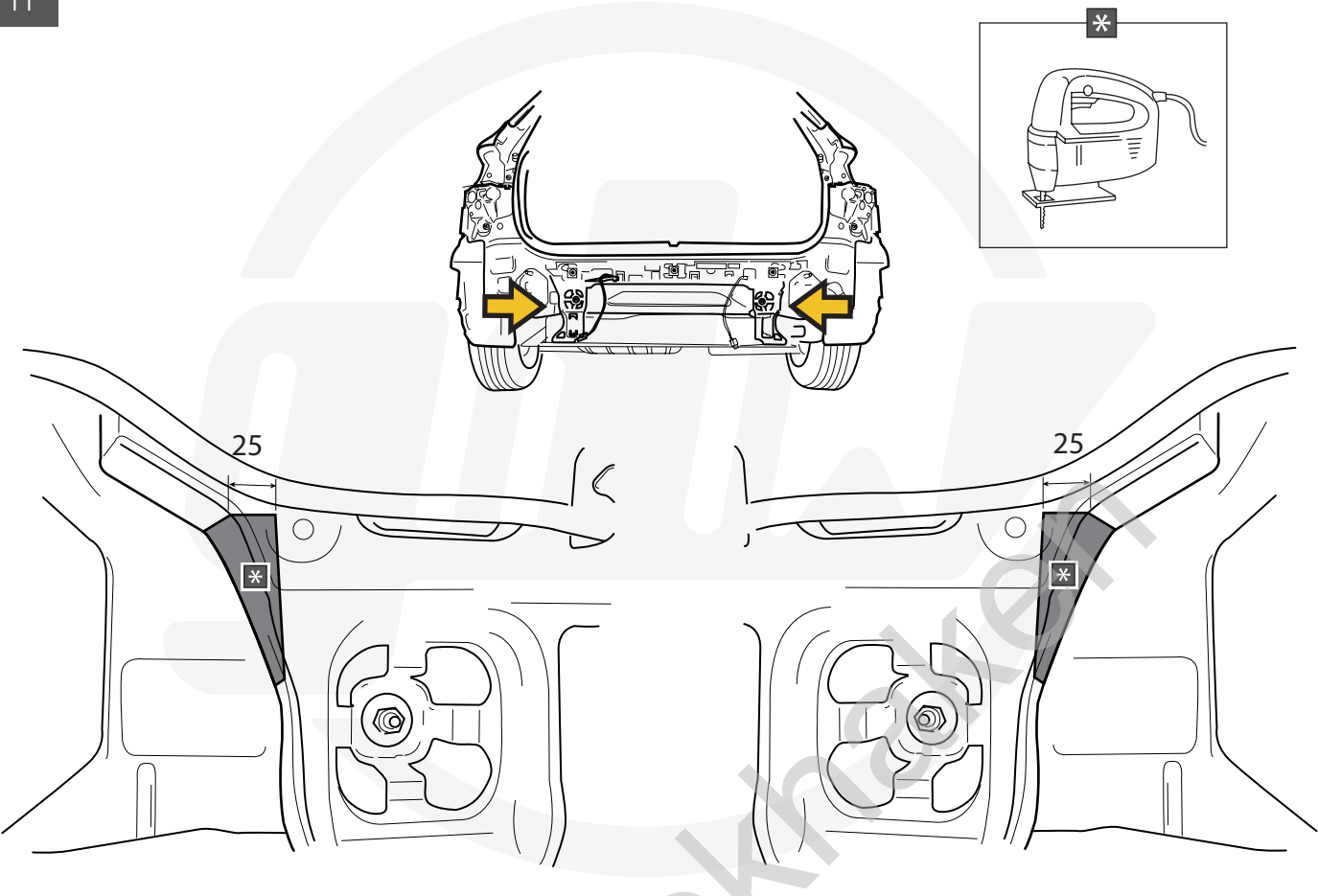

12

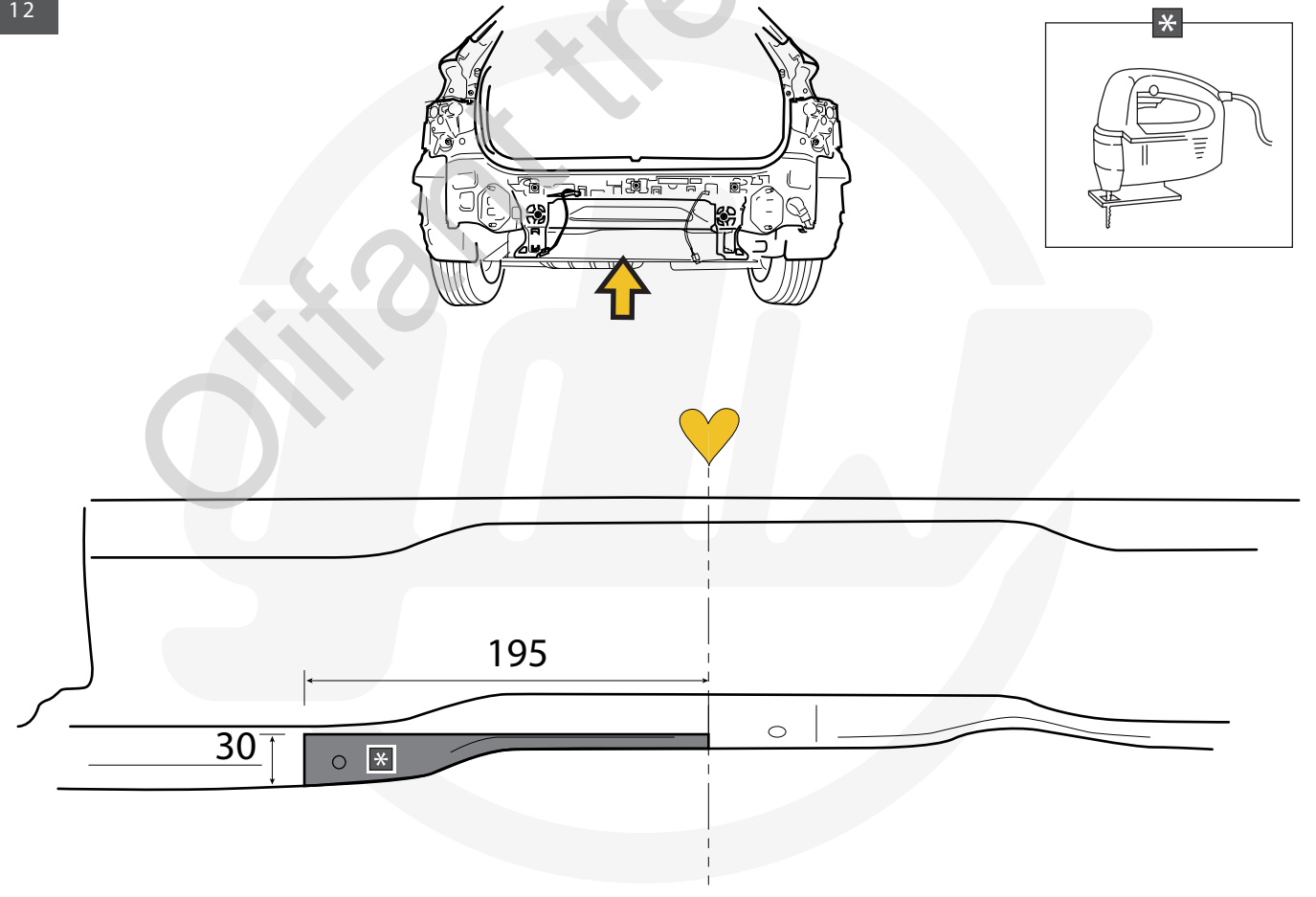

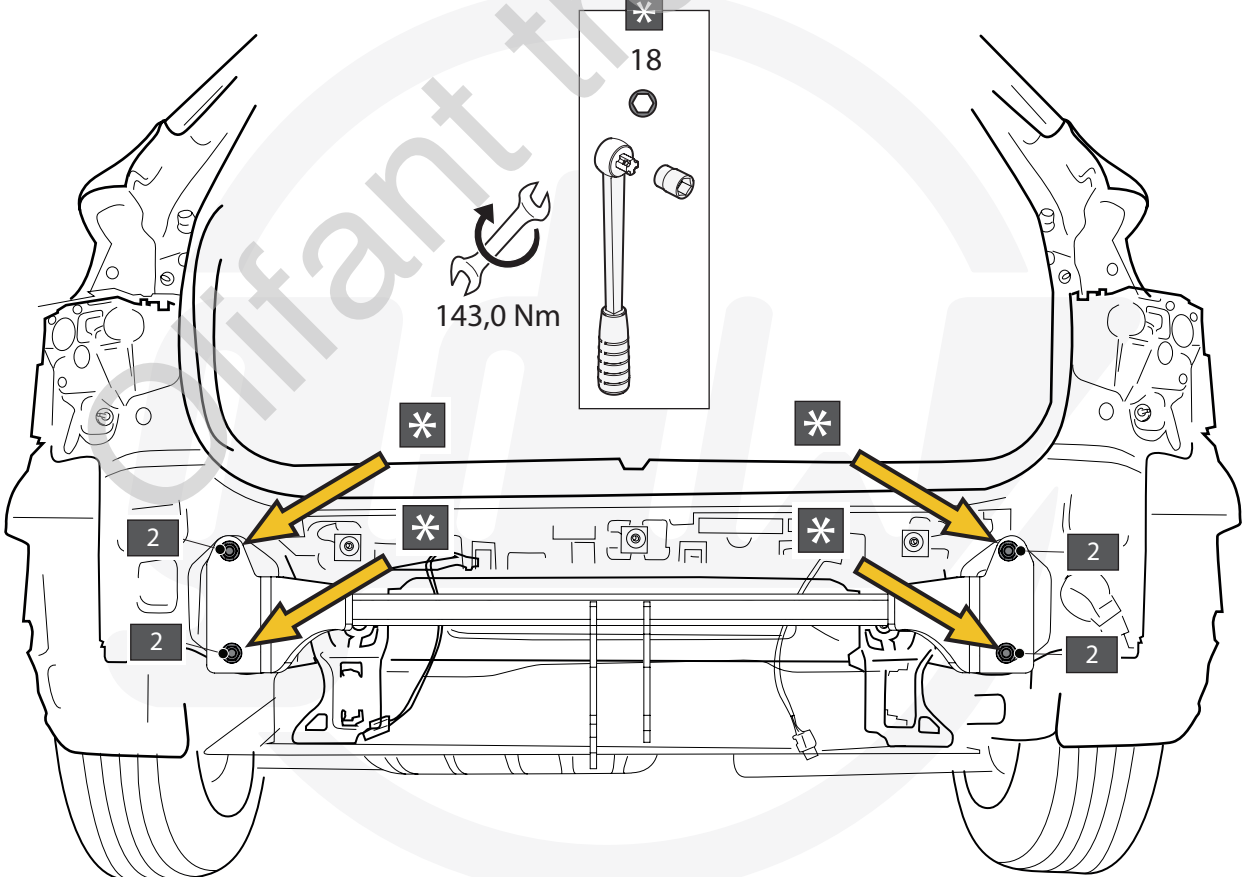
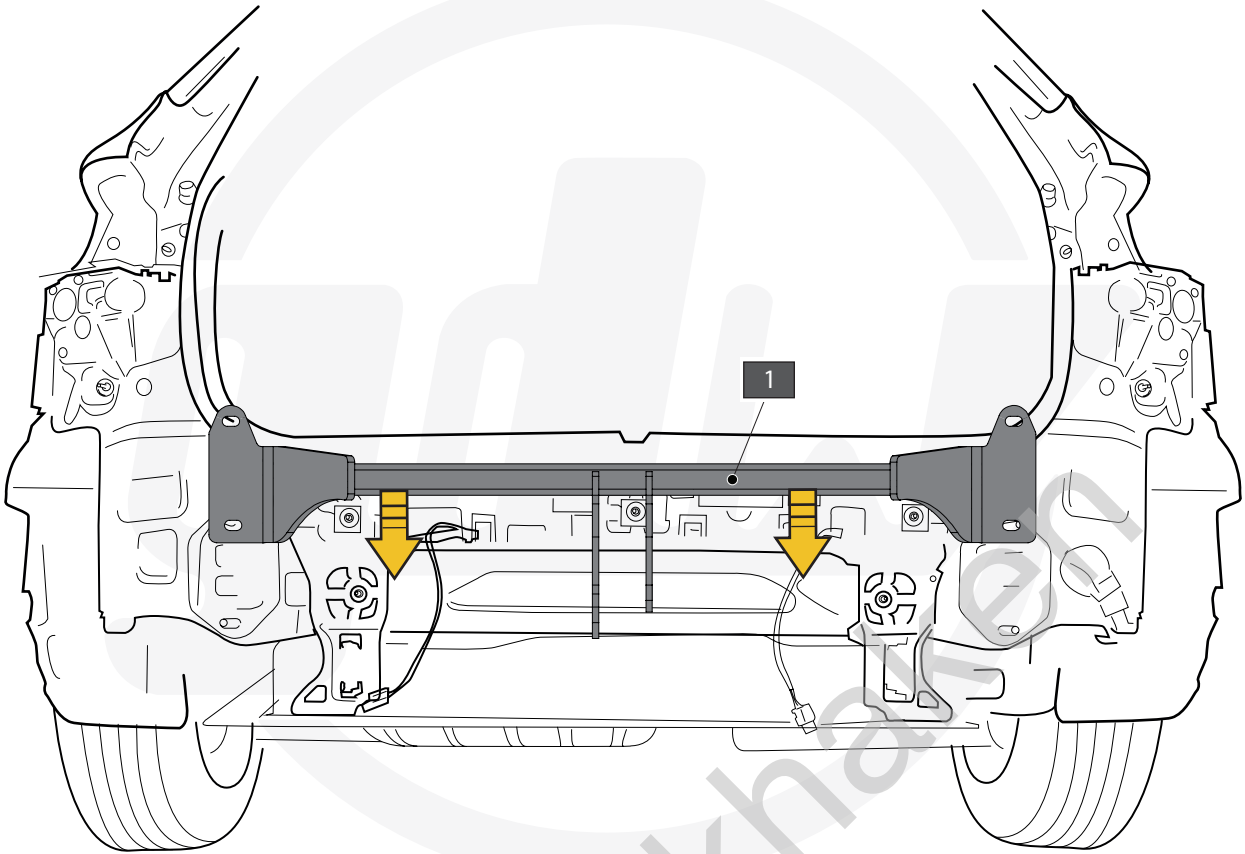

VEHICLES WITH KICK SENSOR

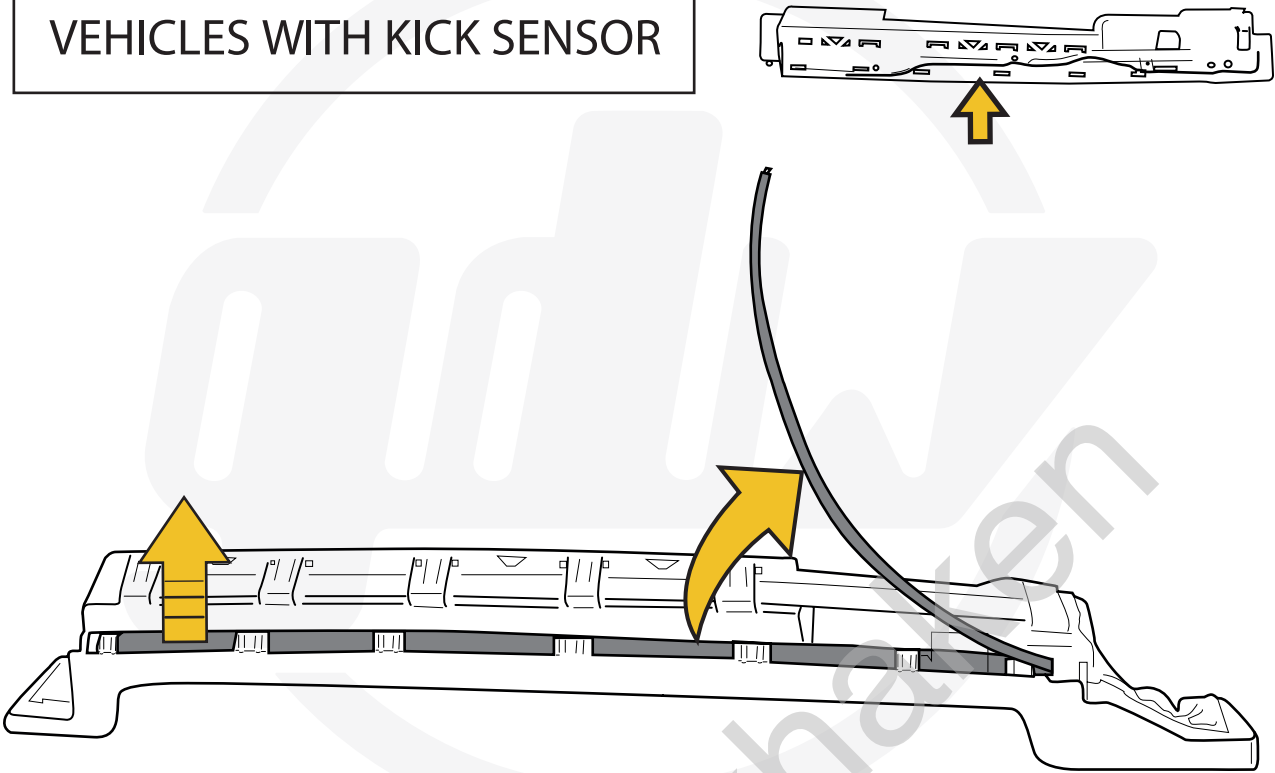

VEHICLES WITH KICK SENSOR

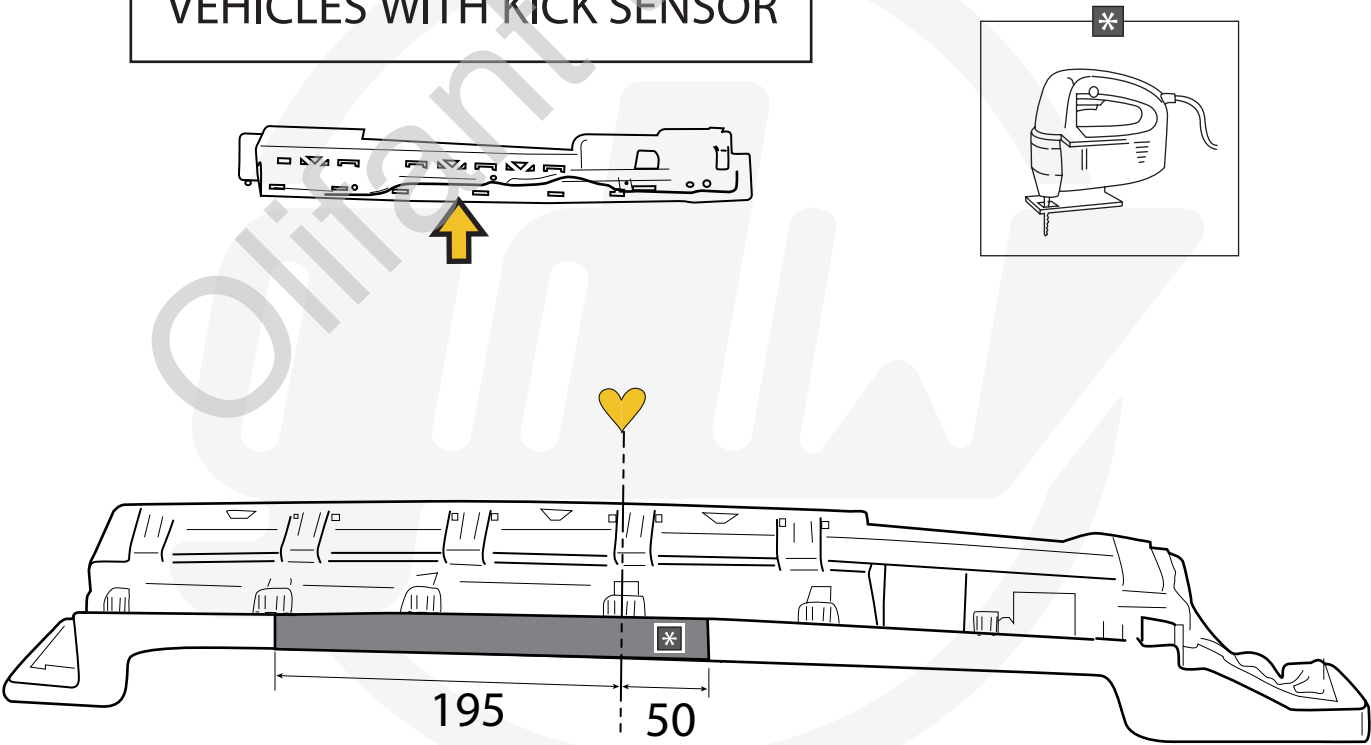

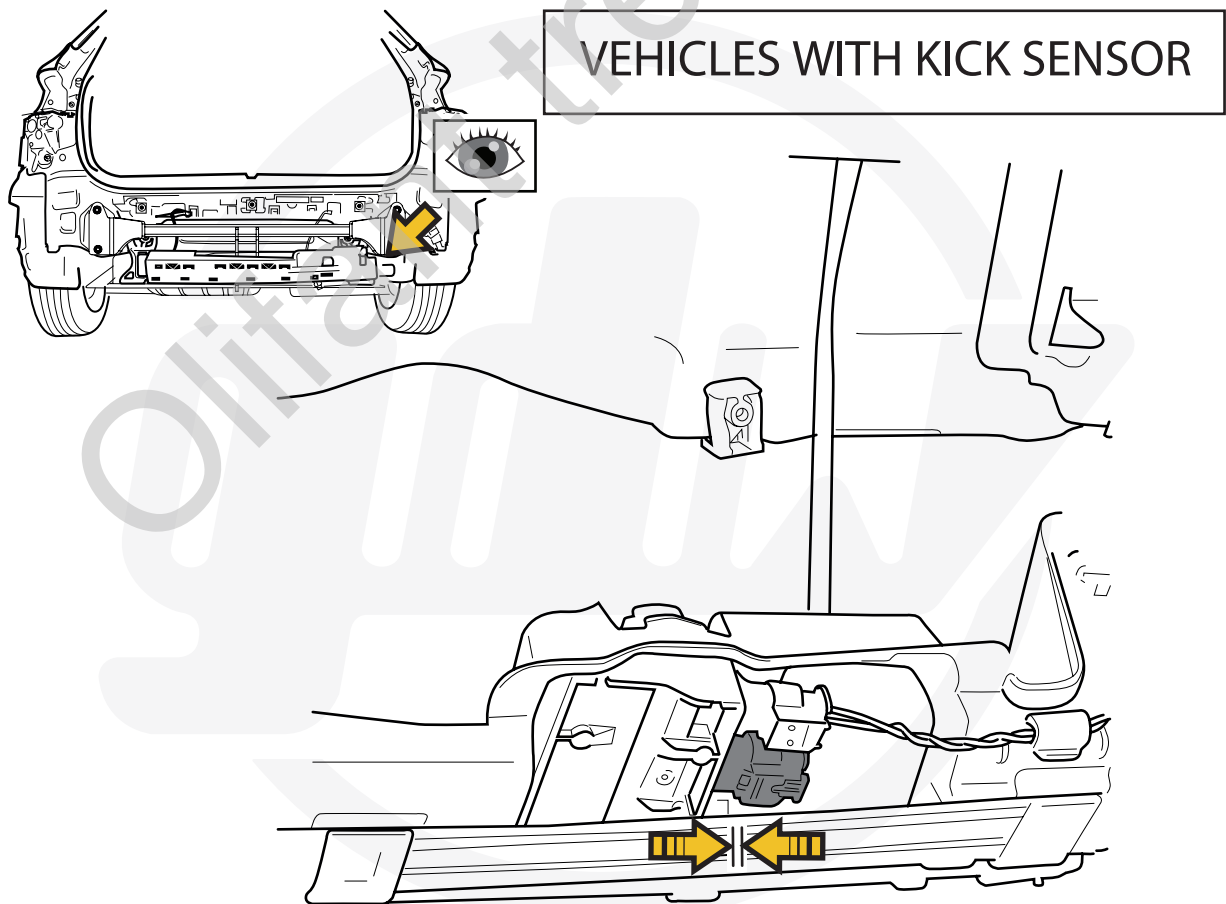
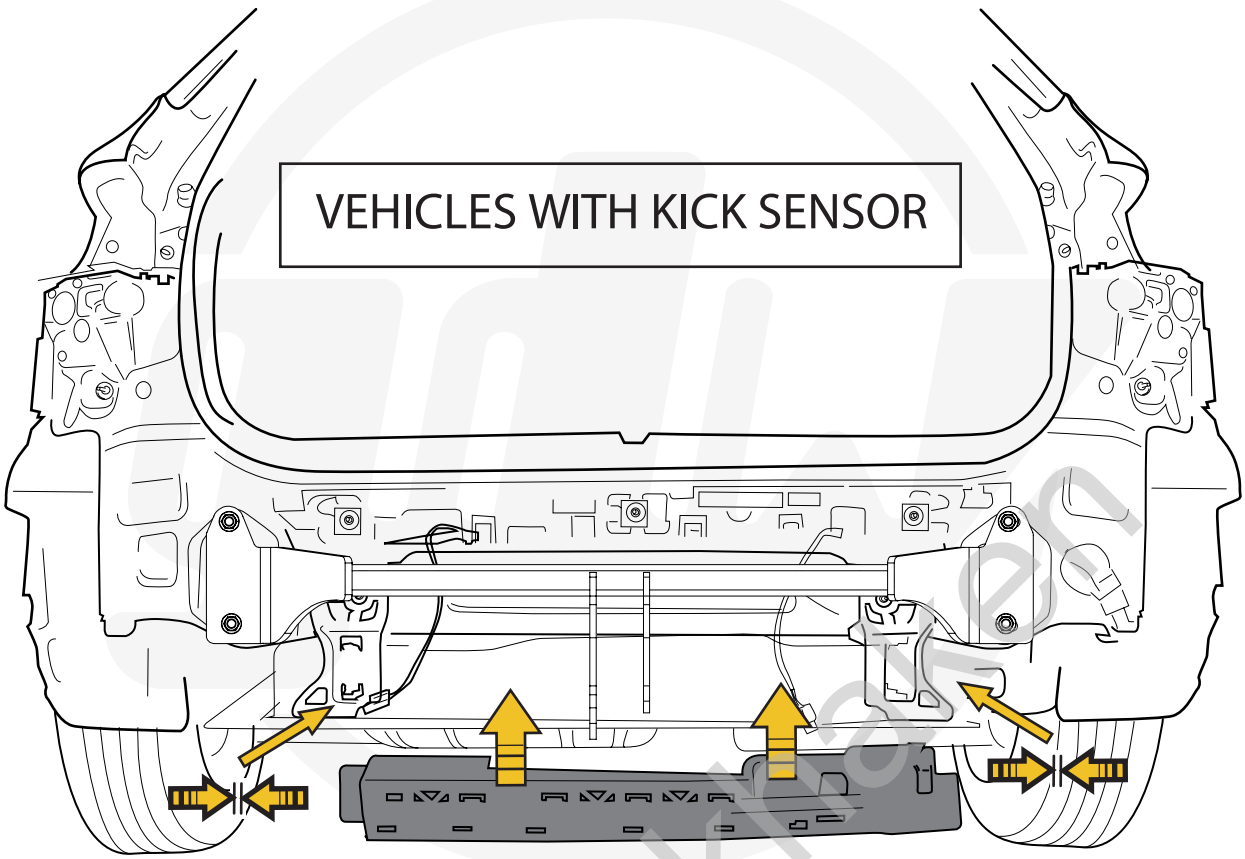

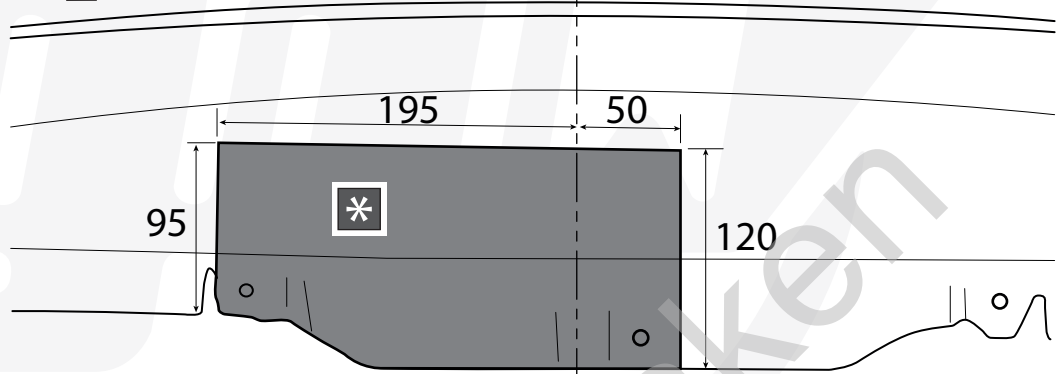
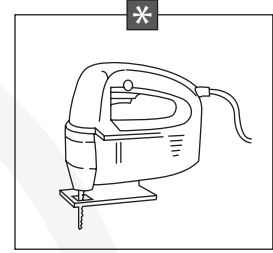
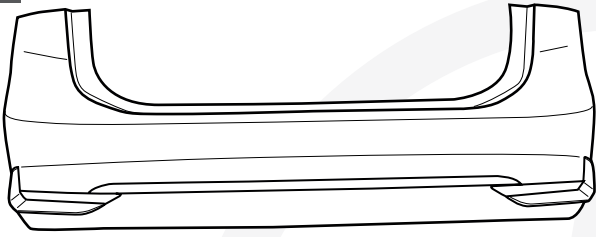

A		X1	GDW REF. 908.095
B		X1	DIN985-M6
C		X2	6,2 X 15,4 X 1,6 (NYLON)
D		X1	GDW REF. 718.16.002
E		X1	GDW REF. 718.16.003
F		X1	GDW REF. 908.094
G		X1	DIN933-M6 X 30

